

# **PRODUCT CATALOGUE**







We have been manufacturing ball screws since 1967 and we deliver them almost all over the world. To provide our customers with the highest quality of the products and co-operation, we keep investing a lot of effort in continuous improvement. Thanks to this effort, every year we fight for the top positions in the leading innovative competitions. A certificate of quality in compliance with EN ISO 9001:2008 proves that our quality management system is at a high level. We also aim for maximum support of the industrial machinery

development activities in our area, for which we participate in the following associations:



Association of  
Engineering  
Technology



CECIMO



Brno Regional Chamber  
of Commerce

## OUR CUSTOMERS APPRECIATE ESPECIALLY THE FOLLOWING CHARACTERISTICS:



### Quality

- We use new state-of-the-art technologies for manufacture and testing.
- Every ball screw undergoes substantial in-process and output inspections.
- We archive measured values for every product.



### Speed of delivery

- Our usual lead times are within six weeks from order placement.
- In exceptional cases we are able to manufacture and deliver in five days from order placement



### Reliability

- We always meet the agreed delivery deadlines.
- In case of customer doubt we immediately address the situation on the spot.



### Development and courage

- We are not afraid of designing and implementing solutions for untypical applications.
- We take up full responsibility for our solutions.
- Thanks to our in-house development department we are very quick and flexible in this designing.



### Customer orientation

- We produce on the basis of client drawings.
- We are able to produce matrices with smaller stop dimensions than required by ISO 3408.
- We like to actively engage in the proposed movement axes of our customers, helping them in correct dimensioning and cost-saving solutions.



### Service

- We repair older ball and trapezoidal screws.
- In the case of an irreparable defect we are able to return the defective ball screw in short-term operation with an offer of a replacement made according to the original screw.

# GENERAL INFORMATION ON BALL SCREWS,FAQS

## 2.1 Application and use

Ball screws (hereinafter BS) are structural elements, which transmit the rotary movement to straight movement with high efficiency (these screws are not self-locking). They feature high rigidity, accuracy and durability.

The ball screws are used in various machinery sectors, especially due to their high efficiency ensured by a low rolling resistance. BSs are most often used in the following sectors:

Application industry	Application example	Precision grade					
		P0	P1	P3	P5	T5	T7
Machine tools industry	Horizontal boring machines		•	•	•		
	Lathes			•	•		
	Grinding machines	•	•				
	Milling machines		•	•	•		
	Machining centres		•	•	•		
	Drilling machines			•	•		
	Wire cutting machines		•	•			
	Laser cutting machines			•	•		
	Electric presses			•	•		
	Bending machines			•			
	Broaching machines			•	•		
	Woodworking machines				•	•	•
Plastic industry	Plastic injection molding machines			•	•		
Automotive industry	Steering systems		•	•			
	Car jacks					•	•
Semiconductor industry	PCB drilling machines		•	•			
	Lithographic machines	•	•				
Aircraft industry	Wing spoiler actuators		•	•			
	Lifting systems					•	•
	Braking systems			•	•		
Industrial robots	Cartesian, articulate or SCARA types		•	•	•		
Metallurgical Industry	Forming lines			•	•		
Nuclear industry	Fuel rod control systems		•	•			
	Refuelling systems		•	•			
Metrology	Three dimensional measuring machines	•	•				
	Microscopes	•	•				
Entertainment industry	Lifting systems of stages in theatres				•	•	•
	Amusement attractions					•	•
Medical industry	X-RAY and other medical machines			•	•		
	Hospital beds					•	•

## 2.2 Standard manufacturing technology for making the ball screw thread

Accuracy and quality of the ball screws are largely dependent on the manufacturing technology selected. Generally, the following technologies are mainly used to produce the ball screw thread:

- Grinding (achieved accuracy class of the ball screw shaft thread pitch up to P1).
- Rolling (achieved accuracy class of the ball screw shaft thread pitch up to T5).

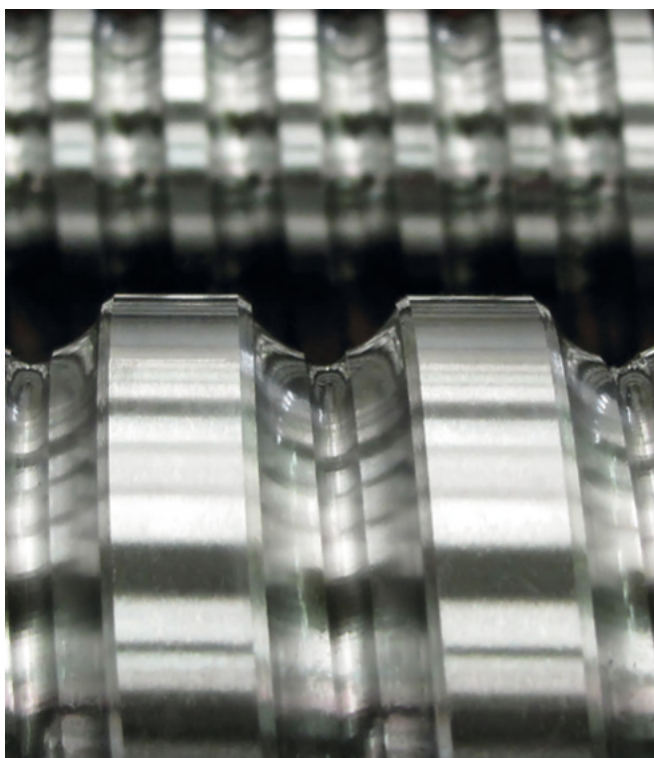

Ground thread

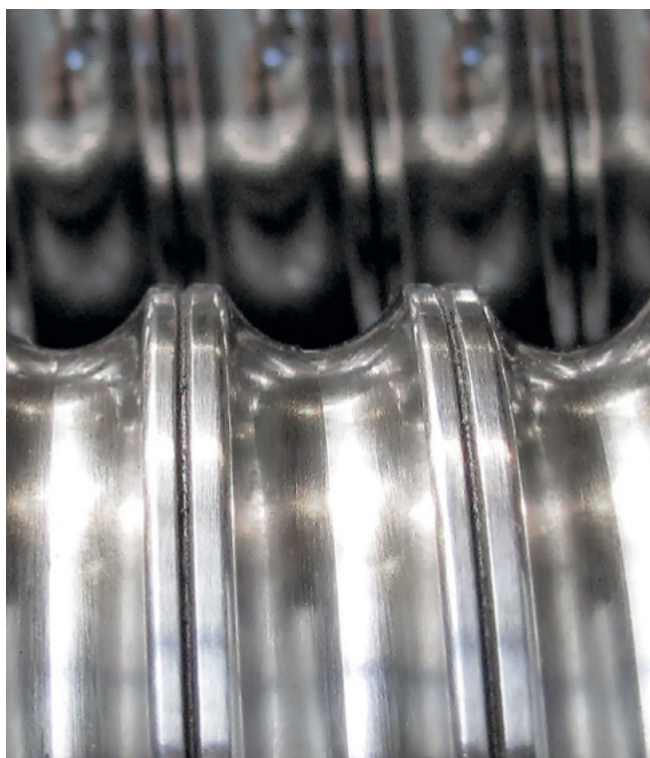

Rolled thread

## 2.3 Ball screw profile

To achieve the maximum transmission efficiency, it is necessary to make an ideal profile of the ball screw thread. The profile is not made of one radius but of two radii with offset (so called gothic arch, see the figure below). This profile shape offers an ideal efficiency to load capacity (ratings) ratio of the ball screw.

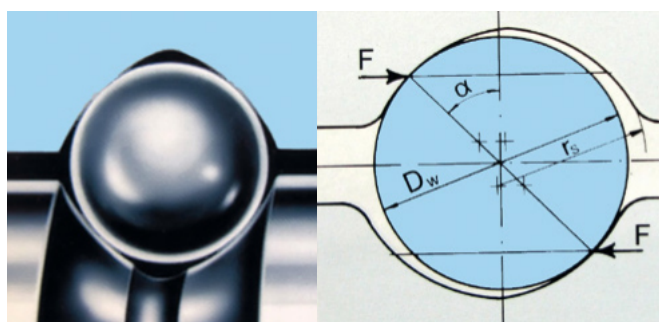

## 2.4 Ball screw preloading methods

Preloading method	Used on the ball nut units	Preloading method diagram
Preload using a spacer ring	AP+A, A+A, B+B+K	
Preload using differential nut thread pitch	APR	
Preload using the difference between individual threads (for multiple-start ball screws)	APV	

## 2.5 Materials used for manufacturing of the ball screws and their heat treatment

To manufacture the ball screw shafts, we use steel with the grade of 42CrMo4. To manufacture the ball nuts, the most often used steel grade is 100CrMn6.

Nuts and the threaded part of the shaft are hardened to 58–60 HRC. The minimum strength of the core and non-hardened parts of the shafts is  $R_m = 800$  MPa. The final quality is tested by long term durability tests followed

by the analysis of the functional parts of the transmission assembly when the specified wear limits are achieved. Based on the achieved information and knowledge of the operating conditions, it is possible to guarantee the actual product lifetime, or to propose an optimum product for the conditions given.

## 2.6 Load capacity (ratings), rigidity and recirculation system lifetime

Another main technical parameter for selection of the ball screw is its load capacity. There are two types of the ball screw load capacity:

a) Static load capacity (Co) is a static load, which corresponds to the permanent deformation of the ball and the running surface in the most stressed touch point; equal to 0.0001 of the ball diameter Dw.

b) Dynamic load capacity (Ca) is a permanent, invariable load, which may be (in theory) transmitted by the ball screw with the basic lifetime parameter  $L_{10} = 1 \times 10^6$  revolutions.

The following equation is used to determine the basic lifetime, which is defined as number of shaft revolutions in relation to the nut body, performed with 90% reliability and with the force F applied, until the first signs of the material fatigue or functional recirculation elements are observed.

$$L_{10} = \left( \frac{C_a}{F} \right)^3 \times 10^6 \text{ (rotation)}$$

Rigidity of the ball transmission (R) is defined as a ratio of the external force applied (Fa) and the nut axial shift Δ on the ball screw shaft:  $R = Fa / \Delta (N/\mu m)$

To achieve high rigidity and ensure axial play elimination, so called preload Fv is applied to the transmission chain, so that the ratio of the loading axial force Fa, which should not cause any play in the transmission yet, and preload Fv, satisfies the following condition:  $Fa / Fv = 2,83$

To determine the force Fa and thus the preload value, it is necessary to consider this in a reasonable manner with respect to the time slope of the ball screw load, since the preload reduces the transmission assembly lifetime.

## 2.7 Ball screw mounting accuracy



The ball screws require accurate and stiff mounting. The ball screw and guiding surface axes must be parallel within 0.02 mm / 1,000 mm and the ball nut unit must ensure its perpendicularity with respect to the longitudinal axis within 0.01 mm / 100 mm. The ball nut units may be loaded only in the axial direction.

The long, narrow ball screws must be designed so that their movement assembly can compensate shaft deflections resulting from its weight (supports or the driven nut design modifications).

## 2.8 Ball nut mounting and removal procedure

If the nut needs to be removed from the delivered ball screw and then mounted back again, proceed as follows (please keep in mind that in the event of ball screw da-

mage due to unprofessional installation or removal, the warranty on the damaged product becomes invalid):

Step #	Activity description	Procedure diagram
1	To avoid pouring the balls out when the nut is removed, it is necessary to push the assembly tube towards the shaft thread face. The tube diameter can be found in the tables for individual versions. Please contact our technical support in order to find the tube diameter.	
2	Slowly rotate the ball nut to move it to the tube.	
3	Now the nut with the tube may be moved from the ball screw. Please keep in mind that if the assembly tube is pulled out from the ball nut, the balls will fall out of the nut unit.	

# BALL SCREW SELECTION GUIDE

A complete configurator of ball screws is freely available on our website. Partial steps of this configurator are shown below. The selection of the ball screw version from the offered production range is driven mainly by the functional

specification, required features and operating conditions. If you need any assistance with the design proposal, please contact our technical support, who will help you with the design proposal.

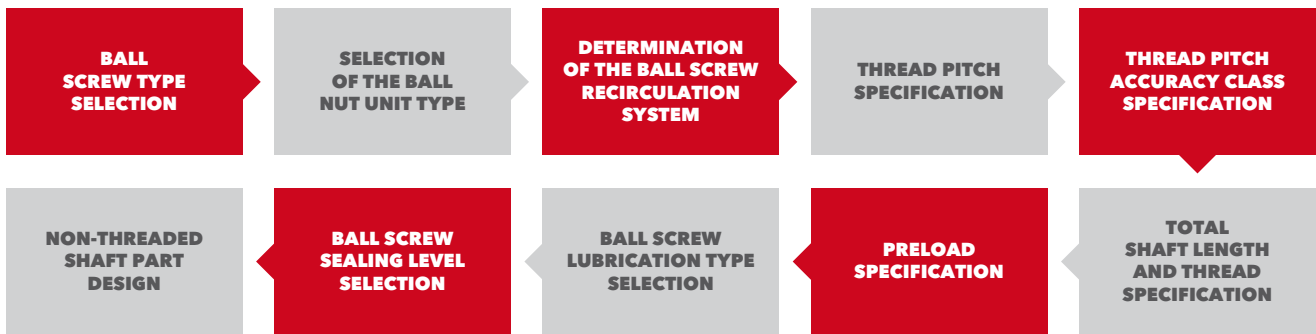









## 3.1 Ball screw type selection

At the beginning of the ball screw design it is necessary to select the ball screw type carefully. This selection should

be based on the requirements on the ball screw accuracy, motion quality, price, etc. There are four basic variants:

 <b>Precise Screw</b>	<p>Grounded screws for precise applications</p> <ul style="list-style-type: none"> <li>• Ground thread</li> <li>• Accuracy classes: P1, P3, P5</li> <li>• Preloaded and non-preloaded nuts</li> <li>• Length up to 15,500 mm</li> <li>• Diameter up to 180 mm</li> </ul>	
 <b>Heavy Duty Screw</b>	<p>Power with no compromise</p> <ul style="list-style-type: none"> <li>• Ground thread</li> <li>• Accuracy classes: P3, P5</li> <li>• Dynamic loads up to 4,000,000 N</li> <li>• Diameter up to 200 mm</li> </ul>	
 <b>Special Screw</b>	<p>When customised performance requirements are necessary</p> <ul style="list-style-type: none"> <li>• Telescopic Ball Screws</li> <li>• Threadless Ball Screws</li> <li>• Ball Screws with Driven Nuts</li> </ul>	
 <b>Basic Screw</b>	<p>Basic quality for fair price</p> <ul style="list-style-type: none"> <li>• Rolled thread</li> <li>• Accuracy classes: T5 and T7</li> <li>• Preloaded and non-preloaded nuts</li> <li>• Length up to 5,600 mm</li> <li>• Diameter up to 63 mm</li> </ul>	









### 3.2 Selection of the ball nut unit type

Description	Marking	Picture	Description	Marking	Picture
Non-preloaded nut without flange	A		Preloaded nut with flange	APR	
Non-preloaded nut with flange	AP		End cap return high-speed (fast-running) preloaded nut with flange	APV	
Double preloaded nut without flange	A+A		Non-preloaded nut with flange for shafts with rolled thread	APE	
Double preloaded nut with flange	AP+A		Driven nut with inserted bearings	RMV	

### 3.3 Determination of the ball screw recirculation system

Nominal thread diameter  $d_0$  is selected in the tables (chapter 4) based on the dimensions available and the required application. Nominal thread diameter determines the ball screw shaft column strength depending on

its length and support. The nominal thread diameter  $d_0$  is used to determine its maximum speed  $n_{max}$  related to the circulation velocity of the balls in the recirculation and lubrication system used.

Recirculation system name	Maximum speed coefficient	Version marking	Recirculation unit design	Recirculation system function	Recirculation system information
External ball recirculation - axially inserted	$n_{max} = \frac{125\,000}{d_0}$	EX - A			Housing dimensions in accordance with ISO3408, a higher load capacity with the same nut length compared to the internal return system.
External ball recirculation - radially inserted	$n_{max} = \frac{125\,000}{d_0}$	EX - R			Housing dimensions in accordance with ISO3408, a higher load capacity with the same nut length compared to the internal return system.
External ball recirculation - endcap	$n_{max} = \frac{125\,000}{d_0}$	EX - E			Housing dimensions bigger than in accordance with ISO3408, a return system suitable for high pitches and multiple-start ball screws.
Internal ball recirculation	$n_{max} = \frac{100\,000}{d_0}$	IN			Housing dimensions smaller than in accordance with ISO3408, a lower load capacity with the same nut length compared to the return systems with radially or axially inserted segments.

### 3.4 Thread pitch specification

Thread pitch P determines the nut travel per one rotation of the ball screw shaft. The standard offered combinations

of the thread diameter and pitch can be found in the tables (see the chapter 4).

### 3.5 Thread pitch accuracy class specification

Thread accuracy class - the ball screws are offered in several accuracy classes, which are described in more detail in the ISO 3408 standard. The highest accuracy class are often used in cases where very precise positioning is required (e.g. machine tools). Lower accuracy classes are often used for applications where the positioning precision requirements are not high (e.g. manipulators). The accuracy classes can be found in the table below:

Pitch tolerance on the thread length of 300 mm (mm)	Ground thread			Rolled thread	
	P1	P3	P5	T5	T7
	0.006	0.012	0.023	0.023	0.052

### 3.6 Shaft and thread lengths

The total shaft and thread lengths are among the most important parameters of the complete ball screw. The shaft lengths offered are technologically limited and

they are directly related to the thread accuracy and other parameters selected. The length limitations are described in the table below.

Recommended length of the thread (mm)	Class Accuracy	Nominal screw diameter (mm)												
		16	20	25	32	40	50	63	80	100	125	140	160	200
Ground thread	P1	500	1200	1800	2000	4000	4500	5000	5000	5000	5000	4850	4850	3000
	P3	600	1500	3000	3500	4500	5000	8250	8250	8250	8250	6000	6000	3000
	P5	700	1800	3600	4000	5000	7500	12000	13000	15000	15500	6000	6000	3000
Rolled thread	T5	5600	5600	5600	5600	5600	5600	5600	5600	-				
	T7	5600	5600	5600	5600	5600	5600	5600	5600	-				

If the table above does not include the required design, we may not be able to provide this design. In this case, please contact our technical support, who will be pleased to assist you.

### 3.7 Preload specification

Based on the positioning precision and rigidity required, the proper ball nut mating on the shaft method should be selected. The higher the preload, the shorter ball screw transmission lifetime. The following options are available as standard:

- Fitted nut with axial play
- Fitted nut with preload corresponding to 3% of the dynamic load ratings (suitable for precise positioning and less loaded screws)
- Fitted nut with preload corresponding to 5% of the dynamic load ratings (suitable for precise positioning and moderately loaded screws)
- Fitted nut with preload corresponding to 10% of the dynamic load ratings (suitable for precise positioning and more loaded screws)

### 3.8 Ball screw lubrication type selection

The ball screws are lubricated by oil or grease. The lubrication method and the lubricants used are the same as for rolling bearings. The basic amount of lubricant for the specific ball nut unit is specified and recommended on request.

#### Oil lubrication

In general, the ball screws are lubricated with the same oils as the rolling bearings, i.e. with transmission or bearing mineral oils with the minimum viscosity of 50 mm<sup>2</sup>/s at the temperature of 40 °C. The oil amount is dependent on the operating conditions.

#### Grease lubrication

If the ball screw is lubricated by grease, the class 2 acc. to DIN 51825 is recommended. The following standard greases can be used:

- KLÜBER Isoflex NBU 15
- OPTIMOL OPTITEMPTT1

During the normal machine operation, the grease should be added every 6 to 10 months. Never mix the greases with different properties during the machine operation.

### 3.9 Ball screw sealing level selection

The sealing level is dependent on the working environment of the ball screw. There are 3 standard sealing types available:

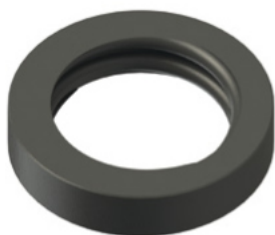

Polyamide wiper ring

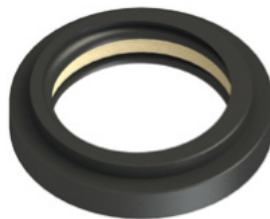

Polyamide wiper ring with felt ring



Polyamide wiper ring with felt ring and brush

### 3.10 Non-threaded shaft part design

The standard shaft ends are shown in the „Standard ball screw ends“ catalogue. Other design proposals of the non-threaded ends based on the customer's require-

ments are possible. If you are interested in help with the design proposal, our technical support department will be pleased to assist you.

# BALL SCREW DESIGN

## 4.1 Precise screw

This type of ball screw is mostly used for the practical purposes due to its versatility, excellent technical parameters

and wide range of variants. Usually they are screws with ground threads.

Basic technical parameters:

- Diameter from 12 to 180 mm
- Length up to 15.5 m
- Accuracy classes P1 to P5
- Minimum strength of the shaft material is  $R_m = 800 \text{ MPa}$
- Efficiency approx. 94–97%
- Operating temperature  $-40 \text{ }^\circ\text{C}$  to  $+80 \text{ }^\circ\text{C}$  (acc. to the lubricant type)

Category characteristics:

- Precise positioning screws
- Wide choice of sizes and pitches
- Delivered with the required preload adjusted

Application:

- Grinding machine tools
- Milling and boring machine tools
- Machining centres
- Precision lathes
- Others



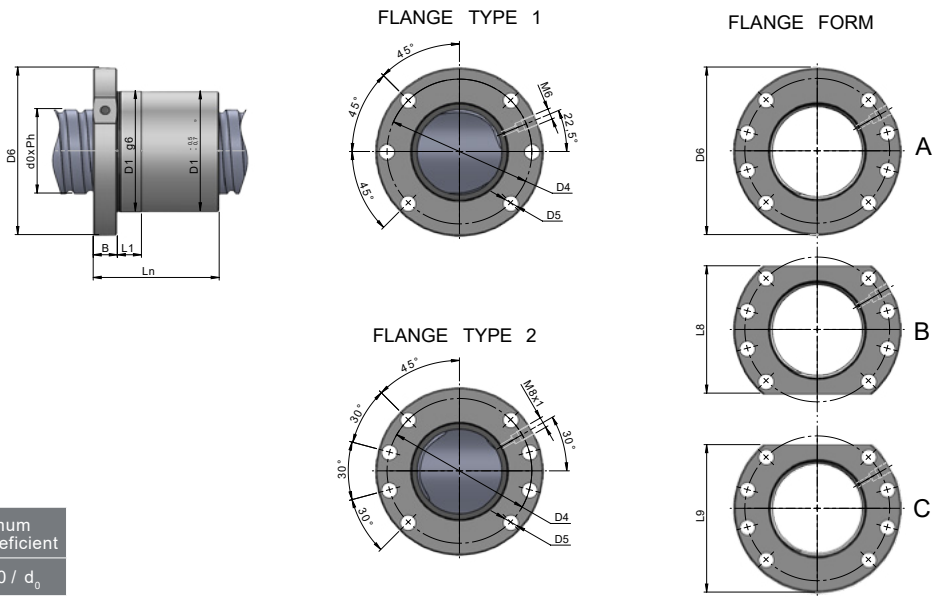

Recirculation system	Maximum speed coefficient
IN	100 000 / d <sub>0</sub>

Diameter d <sub>0</sub>	Pitch P <sub>h</sub> mm	Number of effective turns i	Length of the nut L <sub>n</sub> mm	Ball nut diameter D <sub>1</sub> mm	L <sub>1</sub> mm	Flange diameter D <sub>6</sub> mm	Flange width B mm	D <sub>4</sub> mm	D <sub>5</sub> mm	Flange type	Flange form		Lubrication hole [-]	Ball diameter D <sub>w</sub> mm	C <sub>am</sub> [N]	C <sub>om</sub> [N]
											L <sub>8</sub> mm	L <sub>9</sub> mm				
20	5	3	41	36	10	58	10	47	6,6	1	44	51	M6	3,5	13 714	23 388
	5	4	46	36	10	58	10	47	6,6	1	44	51	M6	3,5	17 564	21 184
25	5	3	42	40	10	62	10	51	6,6	1	48	55	M6	3,5	16 010	31 617
	5	4	47	40	10	62	10	51	6,6	1	48	55	M6	3,5	20 504	42 156
	10	2	50	40	10	62	10	51	6,6	1	48	55	M6	3,5	11 214	20 960
	10	3	62	40	10	62	10	51	6,6	1	48	55	M6	3,5	15 893	31 440
32	5	3	43	50	12	80	12	65	9	2	62	71	M6	3,5	18 056	41 591
	5	4	48	50	12	80	12	65	9	2	62	71	M6	3,5	23 125	55 455
	5	5	53	50	12	80	12	65	9	2	62	71	M6	3,5	28 017	69 318
	5	6	59	50	12	80	12	65	9	2	62	71	M6	3,5	32 773	83 182
	6	3	48	50	12	80	12	65	9	2	62	71	M6	3,969	21 736	47 741
	6	4	54	50	12	80	12	65	9	2	62	71	M6	3,969	27 837	63 654
	6	5	60	50	12	80	12	65	9	2	62	71	M6	3,969	32 727	79 568
	8	4	66	50	12	80	12	65	9	2	62	71	M6	5	35 700	72 849
	8	5	74	50	12	80	12	65	9	2	62	71	M6	5	43 252	91 061
	10	3	68	50	12	80	12	65	9	2	62	71	M6	6,35	37 128	66 242
	10	4	78	50	12	80	12	65	9	2	62	71	M6	6,35	47 549	88 323
	12	3	78	50	12	80	12	65	9	2	62	71	M6	6,35	37 033	66 113
12	4	90	50	12	80	12	65	9	2	62	71	M6	6,35	47 429	88 150	
40	5	3	45	63	14	93	14	78	9	2	70	81,5	M8X1	3,5	20 106	53 229
	5	4	50	63	14	93	14	78	9	2	70	81,5	M8X1	3,5	25 750	70 973
	5	5	55	63	14	93	14	78	9	2	70	81,5	M8X1	3,5	31 197	88 716
	5	6	61	63	14	93	14	78	9	2	70	81,5	M8X1	3,5	36 493	106 459
	6	3	49	63	14	93	14	78	9	2	70	81,5	M8X1	3,969	24 157	60 777
	6	4	56	63	14	93	14	78	9	2	70	81,5	M8X1	3,969	30 937	81 037
	6	5	61	63	14	93	14	78	9	2	70	81,5	M8X1	3,969	37 482	101 296

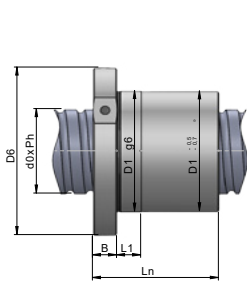

FLANGE TYPE 1

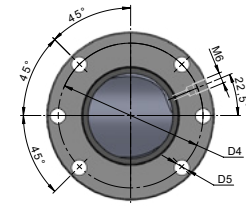

FLANGE TYPE 2

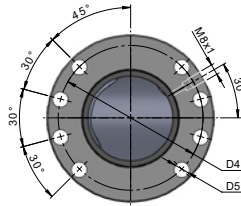

FLANGE FORM

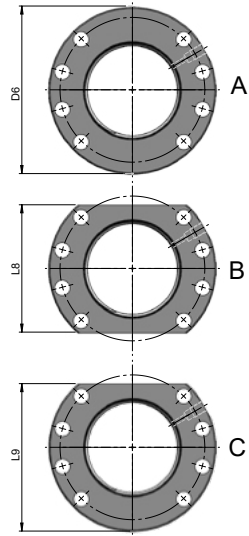

Recirculation system	Maximum speed coefficient
IN	100 000 / d <sub>0</sub>

Diameter d <sub>0</sub>	Pitch P <sub>n</sub> mm	Number of effective turns i	Length of the nut L <sub>n</sub> mm	Ball nut diameter D <sub>1</sub> mm	L <sub>1</sub> mm	Flange diameter D <sub>6</sub> mm	Flange width B mm	D <sub>4</sub> mm	D <sub>5</sub> mm	Flange type	Flange form		Lubrication hole [-]	Ball diameter D <sub>w</sub> mm	C <sub>am</sub> [N]	C <sub>om</sub> [N]
											L <sub>2</sub> mm	L <sub>3</sub> mm				
40	8	3	60	63	14	93	14	78	9	2	70	81,5	M8X1	5	31 746	71 593
	8	4	68	63	14	93	14	78	9	2	70	81,5	M8X1	5	40 657	95 457
	8	5	76	63	14	93	14	78	9	2	70	81,5	M8X1	5	49 258	119 321
	8	6	85	63	14	93	14	78	9	2	70	81,5	M8X1	5	57 620	143 185
	10	3	70	63	14	93	14	78	9	2	70	81,5	M8X1	6,35	43 004	88 036
	10	4	82	63	14	93	14	78	9	2	70	81,5	M8X1	6,35	55 075	117 381
	12	4	89	63	14	93	14	78	9	2	70	81,5	M8X1	7,144	64 691	132 303
	12	5	100	63	14	93	14	78	9	2	70	81,5	M8X1	7,144	78 376	165 379
	15	2	74	63	14	93	14	78	9	2	70	81,5	M8X1	7,144	35 534	65 998
	15	3	92	63	14	93	14	78	9	2	70	81,5	M8X1	7,144	50 360	98 997
15	4	108	63	14	93	14	78	9	2	70	81,5	M8X1	7,144	64 496	131 996	
50	5	4	52	75	16	110	16	93	11	2	85	97,5	M8X1	3,5	28 528	90 922
	5	5	57	75	16	110	16	93	11	2	85	97,5	M8X1	3,5	34 564	113 652
	5	6	63	75	16	110	16	93	11	2	85	97,5	M8X1	3,5	40 431	136 383
	8	3	63	75	16	110	16	93	11	2	85	97,5	M8X1	5	36 251	95 297
	8	4	71	75	16	110	16	93	11	2	85	97,5	M8X1	5	46 426	127 063
	8	5	79	75	16	110	16	93	11	2	85	97,5	M8X1	5	56 248	158 828
	8	6	88	75	16	110	16	93	11	2	85	97,5	M8X1	5	65 797	190 594
	10	3	72	75	16	110	16	93	11	2	85	97,5	M8X1	6,35	48 931	115 375
	10	4	82	75	16	110	16	93	11	2	85	97,5	M8X1	6,35	62 666	153 833
	10	5	92	75	16	110	16	93	11	2	85	97,5	M8X1	6,35	75 924	192 291
	10	6	104	75	16	110	16	93	11	2	85	97,5	M8X1	6,35	88 812	230 750
	12	4	94	75	16	110	16	93	11	2	85	97,5	M8X1	7,938	82 121	182 879
12	5	105	75	16	110	16	93	11	2	85	97,5	M8X1	7,938	99 949	228 599	
12	6	119	75	16	110	16	93	11	2	85	97,5	M8X1	7,938	116 384	274 318	

Diameter d <sub>0</sub>	Pitch P <sub>h</sub>	Number of effective turns i	Length of the nut L <sub>n</sub>	Ball nut diameter D <sub>1</sub>	L <sub>1</sub>	Flange diameter D <sub>6</sub>	Flange width B	D <sub>4</sub>	D <sub>5</sub>	Flange type	Flange form		Lubrication hole	Ball diameter D <sub>w</sub>	C <sub>am</sub>	C <sub>om</sub>
											L <sub>8</sub>	L <sub>9</sub>				
	mm	i	mm	mm	mm	mm	mm	mm	mm	-	mm	mm	[-]	mm	[N]	[N]
50	15	3	94	75	16	110	16	93	11	2	85	97,5	M8X1	7,938	63 996	136 952
	15	4	110	75	16	110	16	93	11	2	85	97,5	M8X1	7,938	81 960	182 602
	20	3	111	75	16	110	16	93	11	2	85	97,5	M8X1	7,938	63 726	136 507
	20	4	133	75	16	110	16	93	11	2	85	97,5	M8X1	7,938	81 614	182 009
63	5	4	54	90	18	125	18	108	11	2	96	110	M8X1	3,5	31 656	117 528
	5	5	59	90	18	125	18	108	11	2	96	110	M8X1	3,5	38 353	146 910
	5	6	65	90	18	125	18	108	11	2	96	110	M8X1	3,5	44 864	176 292
	10	3	75	90	18	125	18	108	11	2	96	110	M8X1	6,35	54 639	148 343
	10	4	85	90	18	125	18	108	11	2	96	110	M8X1	6,35	69 976	197 791
	10	5	94	90	18	125	18	108	11	2	96	110	M8X1	6,35	84 780	247 239
	10	6	106	90	18	125	18	108	11	2	96	110	M8X1	6,35	99 172	296 687
	12	4	98	90	18	125	18	108	11	2	96	110	M8X1	7,938	93 194	239 758
	12	5	109	90	18	125	18	108	11	2	96	110	M8X1	7,938	112 910	299 698
	12	6	123	90	18	125	18	108	11	2	96	110	M8X1	7,938	132 077	359 637
	20	3	122	95	20	135	20	115	13,5	2	104	118	M8X1	10,319	103 227	231 371
	20	4	148	95	20	135	20	115	13,5	2	104	118	M8X1	10,319	132 203	308 494
80	10	4	90	105	20	145	20	125	13,5	2	110	127,5	M8X1	7,144	93 008	292 569
	10	5	99	105	20	145	20	125	13,5	2	110	127,5	M8X1	7,144	112 781	365 712
	10	6	110	105	20	145	20	125	13,5	2	110	127,5	M8X1	7,144	131 926	438 854
	12	4	101	105	20	145	20	125	13,5	2	110	127,5	M8X1	7,938	106 416	319 341
	12	5	112	105	20	145	20	125	13,5	2	110	127,5	M8X1	7,938	128 929	399 176
	12	6	126	105	20	145	20	125	13,5	2	110	127,5	M8X1	7,938	150 815	479 011
	20	3	135	125	25	165	25	145	13,5	2	130	147,5	M8X1	12,7	147 896	346 843
	20	4	157	125	25	165	25	145	13,5	2	130	147,5	M8X1	12,7	189 410	462 457
	20	5	175	125	25	165	25	145	13,5	2	130	147,5	M8X1	12,7	229 480	578 071
	20	6	199	125	25	165	25	145	13,5	2	130	147,5	M8X1	12,7	268 437	693 685
	24	3	140	125	25	165	25	145	13,5	2	130	147,5	M8X1	10,319	117 082	303 384
	24	4	166	125	25	165	25	145	13,5	2	130	147,5	M8X1	10,319	149 947	404 512
100	10	5	98	125	22	165	22	145	13,5	2	130	147,5	M8X1	7,144	125 671	471 718
	10	6	110	125	22	165	22	145	13,5	2	130	147,5	M8X1	7,144	147 005	566 062
	12	3	89	125	22	165	22	145	13,5	2	130	147,5	M8X1	7,938	92 207	307 893
	12	4	102	125	22	165	22	145	13,5	2	130	147,5	M8X1	7,938	118 089	410 524
	12	5	113	125	22	165	22	145	13,5	2	130	147,5	M8X1	7,938	143 071	513 154
	12	6	127	125	22	165	22	145	13,5	2	130	147,5	M8X1	7,938	167 359	615 785
	20	3	133	150	30	202	30	176	17,5	2	155	178,5	M8X1	12,7	168 282	454 550
	20	4	155	150	30	202	30	176	17,5	2	155	178,5	M8X1	12,7	215 519	606 066
	20	5	173	150	30	202	30	176	17,5	2	155	178,5	M8X1	12,7	261 113	757 583
	20	6	197	150	30	202	30	176	17,5	2	155	178,5	M8X1	12,7	305 438	909 099
125	20	4	159	170	30	222	30	196	17,5	2	175	198,5	M8X1	12,7	240 655	779 017
	20	5	177	170	30	222	30	196	17,5	2	175	198,5	M8X1	12,7	291 566	973 771
	20	6	200	170	30	222	30	196	17,5	2	175	198,5	M8X1	12,7	341 062	1 168 525

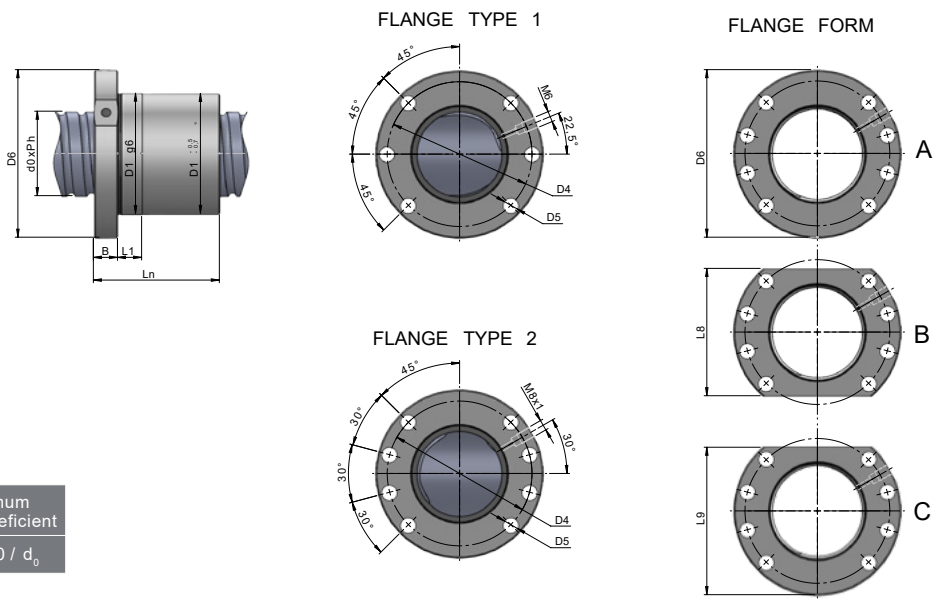

Recirculation system	Maximum speed coefficient
EX-A	125 000 / d <sub>0</sub>

Diameter d <sub>0</sub>	Pitch P <sub>n</sub>	Number of effective turns i	Length of the nut L <sub>n</sub>	Ball nut diameter D <sub>1</sub>	L <sub>1</sub>	Flange diameter D <sub>c</sub>	Flange width B	D <sub>4</sub>	D <sub>5</sub>	Flange type	Flange form		Lubrication hole	Ball diameter D <sub>w</sub>	C <sub>am</sub>	C <sub>cm</sub>
											L <sub>8</sub>	L <sub>9</sub>				
	mm	i	mm	mm	mm	mm	mm	mm	mm	-	mm	mm	[-]	mm	[N]	[N]
40	20	2,8	81	63	14	93	14	78	9	2	70	81,5	M8X1	6,35	43 440	90 656
	20	3,8	101	63	14	93	14	78	9	2	70	81,5	M8X1	6,35	56 487	123 033
	20(P10)	5,6	81	63	14	93	14	78	9	2	70	81,5	M8X1	6,35	78 846	181 312
	20(P10)	7,6	101	63	14	93	14	78	9	2	70	81,5	M8X1	6,35	102 527	246 066
	25	1,8	73	63	14	93	14	78	9	2	70	81,5	M8X1	6,35	29 437	57 870
	25	2,8	98	63	14	93	14	78	9	2	70	81,5	M8X1	6,35	43 045	90 020
	25(P12,5)	3,6	73	63	14	93	14	78	9	2	70	81,5	M8X1	6,35	53 430	115 740
	25(P12,5)	5,6	98	63	14	93	14	78	9	2	70	81,5	M8X1	6,35	78 128	180 040
	40	0,8	59	63	14	93	14	78	9	2	70	81,5	M8X1	6,35	14 598	26 290
	40	1,8	99	63	14	93	14	78	9	2	70	81,5	M8X1	6,35	29 319	59 151
	40	2,8	134	63	14	93	14	78	9	2	70	81,5	M8X1	6,35	42 872	92 013
	40(P20)	1,6	59	63	14	93	14	78	9	2	70	81,5	M8X1	6,35	26 495	52 579
40(P20)	3,6	99	63	14	93	14	78	9	2	70	81,5	M8X1	6,35	53 216	118 303	
40(P20)	5,6	134	63	14	93	14	78	9	2	70	81,5	M8X1	6,35	77 815	184 027	
50	30	1,8	83	75	16	110	16	93	11	2	85	97,5	M8X1	6,35	33 041	74 154
	30	2,8	113	75	16	110	16	93	11	2	85	97,5	M8X1	6,35	48 314	115 351
	30	3,8	143	75	16	110	16	93	11	2	85	97,5	M8X1	6,35	62 825	156 548
	30(P15)	3,6	83	75	16	110	16	93	11	2	85	97,5	M8X1	6,35	59 971	148 309
	30(P15)	5,6	113	75	16	110	16	93	11	2	85	97,5	M8X1	6,35	87 692	230 703
	30(P15)	7,6	143	75	16	110	16	93	11	2	85	97,5	M8X1	6,35	114 030	313 097
	30	1,8	83	82	16	118	16	100	11	2	100	108	M8X1	7,144	40 993	91 339
	30	2,8	113	82	16	118	16	100	11	2	100	108	M8X1	7,144	59 942	142 083
	30	3,8	143	82	16	118	16	100	11	2	100	108	M8X1	7,144	77 945	192 827
	30(P15)	3,6	83	82	16	118	16	100	11	2	100	108	M8X1	7,144	74 404	182 678
	30(P15)	5,6	113	82	16	118	16	100	11	2	100	108	M8X1	7,144	108 797	284 166
	30(P15)	7,6	143	82	16	118	16	100	11	2	100	108	M8X1	7,144	141 473	385 654

Diameter d <sub>0</sub>	Pitch P <sub>h</sub>	Number of effective turns i	Length of the nut L <sub>n</sub>	Ball nut diameter D <sub>1</sub>	L <sub>1</sub>	Flange diameter D <sub>6</sub>	Flange width B	D <sub>4</sub>	D <sub>5</sub>	Flange type	Flange form		Lubrication hole	Ball diameter D <sub>v</sub>	C <sub>am</sub>	C <sub>cm</sub>
											L <sub>8</sub>	L <sub>9</sub>				
	mm	i	mm	mm	mm	mm	mm	mm	mm	-	mm	mm	[ ]	mm	[N]	[N]
50	40	0,8	63	82	16	118	16	100	11	2	100	108	M8X1	7,144	20 077	40 086
	40	1,8	103	82	16	118	16	100	11	2	100	108	M8X1	7,144	40 326	90 194
	40	2,8	143	82	16	118	16	100	11	2	100	108	M8X1	7,144	58 966	140 301
	40(P20)	1,6	63	82	16	118	16	100	11	2	100	108	M8X1	7,144	36 441	80 172
	40(P20)	3,6	103	82	16	118	16	100	11	2	100	108	M8X1	7,144	73 193	180 387
40(P20)	5,6	143	82	16	118	16	100	11	2	100	108	M8X1	7,144	107 026	280 602	
63	30	2,8	115	95	18	135	18	115	13,5	2	104	118	M8X1	7,938	73 810	189 012
	30	3,8	145	95	18	135	18	115	13,5	2	104	118	M8X1	7,938	95 978	256 516
	30	4,8	175	95	18	135	18	115	13,5	2	104	118	M8X1	7,938	117 335	324 020
	30	2,8	124	105	20	145	20	125	13,5	2	110	127,5	M8X1	10,319	107 599	252 586
	30	3,8	154	105	20	145	20	125	13,5	2	110	127,5	M8X1	10,319	139 915	242 795
	30	4,8	184	105	20	145	20	125	13,5	2	110	127,5	M8X1	10,319	171 048	433 004
	40	1,8	105	95	18	135	18	115	13,5	2	104	118	M8X1	7,938	51 267	125 339
	40	2,8	145	95	18	135	18	115	13,5	2	104	118	M8X1	7,938	74 965	194 972
	40	3,8	185	95	18	135	18	115	13,5	2	104	118	M8X1	7,938	97 480	264 605
	40(P20)	3,6	105	95	18	135	18	115	13,5	2	104	118	M8X1	7,938	93 051	250 678
	40(P20)	5,6	145	95	18	135	18	115	13,5	2	104	118	M8X1	7,938	136 063	389 944
	40(P20)	7,6	185	95	18	135	18	115	13,5	2	104	118	M8X1	7,938	176 929	529 210
	40	1,8	112	105	20	145	20	125	13,5	2	110	127,5	M8X1	10,319	72 822	161 082
	40	2,8	152	105	20	145	20	125	13,5	2	110	127,5	M8X1	10,319	106 485	250 572
40	3,8	192	105	20	145	20	125	13,5	2	110	127,5	M8X1	10,319	138 467	340 062	
80	16	2,8	82	125	25	165	25	145	13,5	2	130	147,5	M8X1	10,319	120 522	322 532
	16	3,8	98	125	25	165	25	145	13,5	2	130	147,5	M8X1	10,319	156 720	437 722
	16	4,8	114	125	25	165	25	145	13,5	2	130	147,5	M8X1	10,319	191 593	522 912
	16	5,8	130	125	25	165	25	145	13,5	2	130	147,5	M8X1	10,319	225 455	668 102
	20	2,8	93	125	25	165	25	145	13,5	2	130	147,5	M8X1	10,319	120 356	322 189
	20	3,8	113	125	25	165	25	145	13,5	2	130	147,5	M8X1	10,319	156 504	437 256
	20	4,8	133	125	25	165	25	145	13,5	2	130	147,5	M8X1	10,319	191 328	552 324
	20	5,8	153	125	25	165	25	145	13,5	2	130	147,5	M8X1	10,319	225 143	667 391
	25	2,8	113	125	25	165	25	145	13,5	2	130	147,5	M8X1	10,319	120 097	321 655
	25	3,8	138	125	25	165	25	145	13,5	2	130	147,5	M8X1	10,319	156 167	436 532
	25	4,8	163	125	25	165	25	145	13,5	2	130	147,5	M8X1	10,319	190 916	551 409
	25	2,8	113	125	25	165	25	145	13,5	2	130	147,5	M8X1	12,7	154 995	380 225
	25	3,8	138	125	25	165	25	145	13,5	2	130	147,5	M8X1	12,7	201 547	516 019
	25	4,8	163	125	25	165	25	145	13,5	2	130	147,5	M8X1	12,7	246 394	651 814
	30	2,8	126	125	25	165	25	145	13,5	2	130	147,5	M8X1	10,319	119 782	321 006
	30	3,8	156	125	25	165	25	145	13,5	2	130	147,5	M8X1	10,319	155 757	435 651
	30	4,8	186	125	25	165	25	145	13,5	2	130	147,5	M8X1	10,319	190 415	550 297
	30	5,8	216	125	25	165	25	145	13,5	2	130	147,5	M8X1	10,319	224 069	664 942
	30	2,8	129	125	25	165	25	145	13,5	2	130	147,5	M8X1	12,7	154 595	379 469
	30	3,8	159	125	25	165	25	145	13,5	2	130	147,5	M8X1	12,7	201 026	514 993
30	4,8	189	125	25	165	25	145	13,5	2	130	147,5	M8X1	12,7	245 757	650 518	
30	5,8	219	125	25	165	25	145	13,5	2	130	147,5	M8X1	12,7	289 193	786 043	

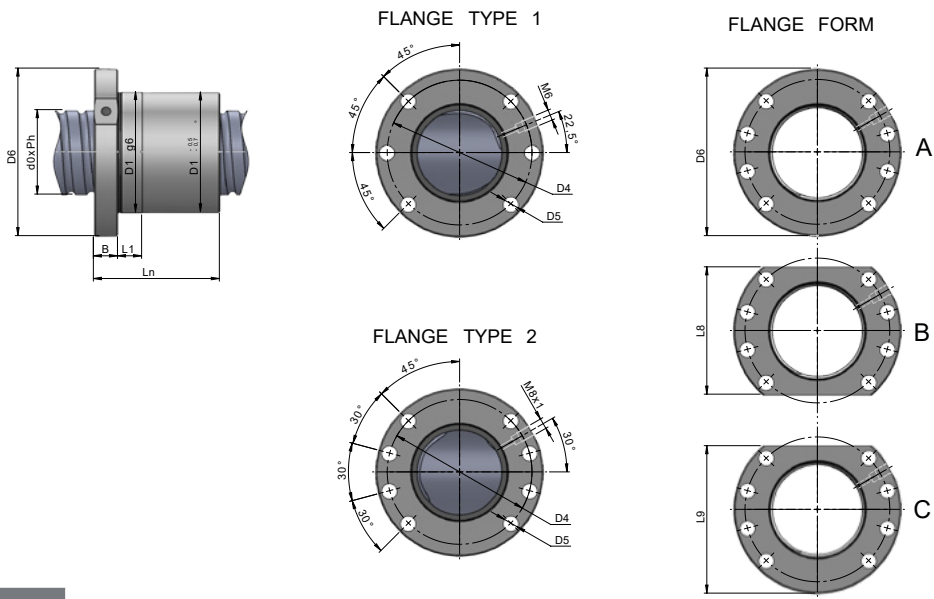

Recirculation system	Maximum speed coefficient
EX-A	125 000 / d <sub>0</sub>

Diameter d <sub>0</sub>	Pitch P <sub>n</sub>	Number of effective turns i	Length of the nut L <sub>n</sub>	Ball nut diameter D <sub>1</sub>	L <sub>1</sub>	Flange diameter D <sub>6</sub>	Flange width B	D <sub>4</sub>	D <sub>5</sub>	Flange type	Flange form		Lubrication hole [-]	Ball diameter D <sub>w</sub>	C <sub>am</sub> [N]	C <sub>om</sub> [N]
											L <sub>8</sub>	L <sub>9</sub>				
	mm	i	mm	mm	mm	mm	mm	mm	mm	-	mm	mm		mm	[N]	[N]
80	40	1,8	111	125	25	165	25	145	13,5	2	130	147,5	M8X1	10,319	81 374	205 311
	40	2,8	151	125	25	165	25	145	13,5	2	130	147,5	M8X1	10,319	118 990	319 372
	40	3,8	191	125	25	165	25	145	13,5	2	130	147,5	M8X1	10,319	154 727	433 434
	40(P20)	3,6	111	125	25	165	25	145	13,5	2	130	147,5	M8X1	10,319	147 698	410 622
	40(P20)	5,6	151	125	25	165	25	145	13,5	2	130	147,5	M8X1	10,319	215 971	638 745
	40(P20)	7,6	191	125	25	165	25	145	13,5	2	130	147,5	M8X1	10,319	280 836	866 868
	40	1,8	117	125	25	165	25	145	13,5	2	130	147,5	M8X1	12,7	105 035	242 720
	40	2,8	157	125	25	165	25	145	13,5	2	130	147,5	M8X1	12,7	153 587	377 565
	40	3,8	197	125	25	165	25	145	13,5	2	130	147,5	M8X1	12,7	199 716	512 409
	40(P20)	3,6	117	125	25	165	25	145	13,5	2	130	147,5	M8X1	12,7	190 642	485 440
	40(P20)	5,6	157	125	25	165	25	145	13,5	2	130	147,5	M8X1	12,7	278 766	755 129
	40(P20)	7,6	197	125	25	165	25	145	13,5	2	130	147,5	M8X1	12,7	362 492	1 024 818
	50	1,8	135	125	25	165	25	145	13,5	2	130	147,5	M8X1	12,7	104 165	241 173
	50	2,8	185	125	25	165	25	145	13,5	2	130	147,5	M8X1	12,7	152 316	375 158
	50	3,8	235	125	25	165	25	145	13,5	2	130	147,5	M8X1	12,7	198 062	509 143
	50(P25)	3,6	135	125	25	165	25	145	13,5	2	130	147,5	M8X1	12,7	189 064	482 346
	50(P25)	5,6	185	125	25	165	25	145	13,5	2	130	147,5	M8X1	12,7	276 459	750 315
	50(P25)	7,6	235	125	25	165	25	145	13,5	2	130	147,5	M8X1	12,7	359 491	1 018 285

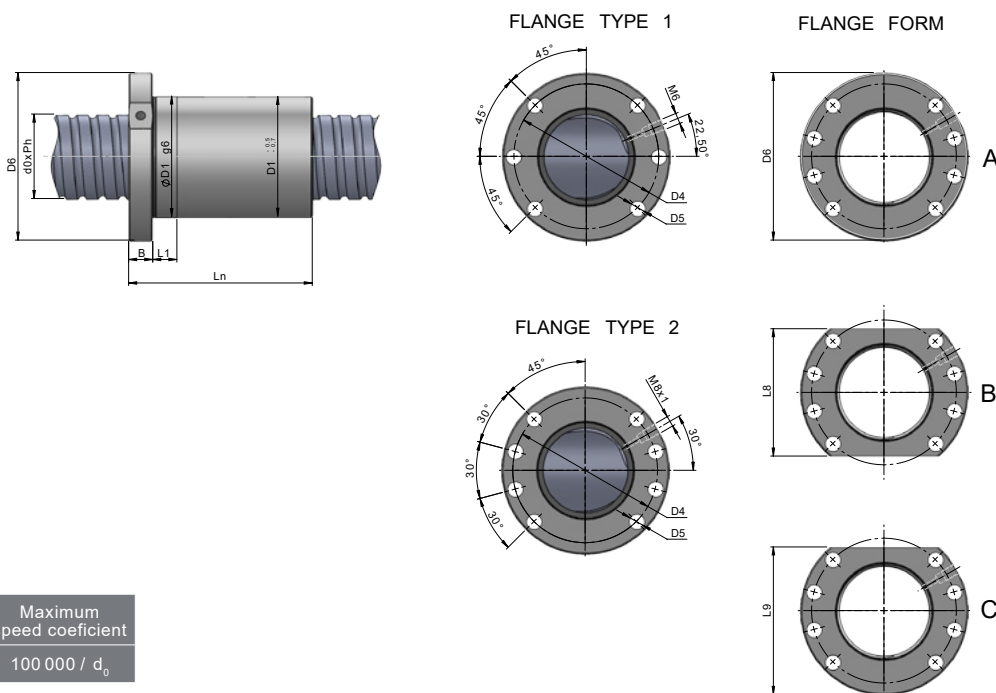

Recirculation system	Maximum speed coefficient
IN	100 000 / d <sub>0</sub>

Diameter d <sub>0</sub>	Pitch P <sub>h</sub> mm	Number of effective turns i	Length of the nut L <sub>n</sub> mm	Ball nut diameter D <sub>1</sub> mm	L <sub>1</sub> mm	Flange diameter D <sub>6</sub> mm	Flange width B mm	D <sub>4</sub> mm	D <sub>5</sub> mm	Flange type	Flange form		Lubrication hole [-]	Ball diameter D <sub>w</sub> mm	C <sub>am</sub> [N]	C <sub>om</sub> [N]
											L <sub>8</sub> mm	L <sub>9</sub> mm				
20	5	3	62	36	10	58	10	47	6,6	1	44	51	M6	3,5	13 714	23 388
	10	2	83	40	10	62	10	51	6,6	1	48	55	M6	3,5	11 214	20 960
32	5	3	64	50	12	80	12	65	9	1	62	71	M6	3,5	18 056	41 591
	5	4	74	50	12	80	12	65	9	1	62	71	M6	3,5	23 125	55 455
	5	5	85	50	12	80	12	65	9	1	62	71	M6	3,5	28 017	69 318
	6	3	72	50	12	80	12	65	9	1	62	71	M6	3,969	21 736	47 741
	6	4	85	50	12	80	12	65	9	1	62	71	M6	3,969	27 837	63 654
	8	3	91	50	12	80	12	65	9	1	62	71	M6	5	27 875	54 636
	8	4	107	50	12	80	12	65	9	1	62	71	M6	5	35 700	72 849
40	10	3	109	50	12	80	12	65	9	1	62	71	M6	6,35	37 128	66 242
	5	3	66	63	14	93	14	78	9	2	70	81,5	M8x1	3,5	20 106	53 229
	5	4	76	63	14	93	14	78	9	2	70	81,5	M8x1	3,5	25 750	70 973
	5	5	87	63	14	93	14	78	9	2	70	81,5	M8x1	3,5	31 197	88 716
	5	6	99	63	14	93	14	78	9	2	70	81,5	M8x1	3,5	36 493	106 459
	6	3	74	63	14	93	14	78	9	2	70	81,5	M8x1	3,969	24 157	60 777
	6	4	87	63	14	93	14	78	9	2	70	81,5	M8x1	3,969	30 937	81 037
	6	5	100	63	14	93	14	78	9	2	70	81,5	M8x1	3,969	37 482	101 296
	8	3	93	63	14	93	14	78	9	2	70	81,5	M8x1	5	31 746	71 593
	8	4	109	63	14	93	14	78	9	2	70	81,5	M8x1	5	40 657	95 457
	8	5	127	63	14	93	14	78	9	2	70	81,5	M8x1	5	49 258	119 321
	10	3	112	63	14	93	14	78	9	2	70	81,5	M8x1	6,35	43 004	88 036
10	4	132	63	14	93	14	78	9	2	70	81,5	M8x1	6,35	55 075	117 381	

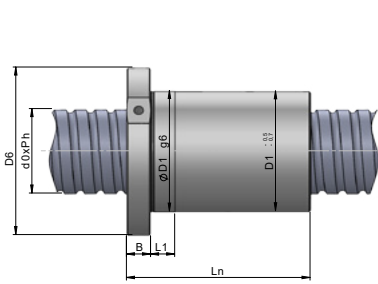

FLANGE TYPE 1

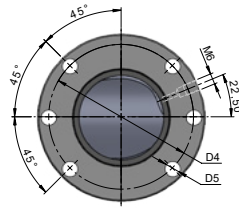

FLANGE FORM

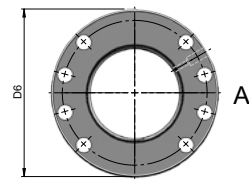

FLANGE TYPE 2

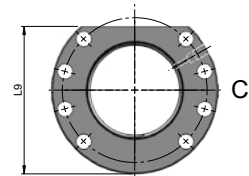
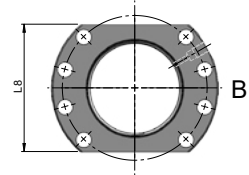
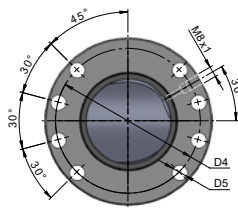

Recirculation system	Maximum speed coefficient
IN	100 000 / d <sub>0</sub>

Diameter d <sub>0</sub>	Pitch P <sub>h</sub> mm	Number of effective turns i	Length of the nut L <sub>n</sub> mm	Ball nut diameter D <sub>1</sub> mm	L <sub>1</sub> mm	Flange diameter D <sub>6</sub> mm	Flange width B mm	D <sub>4</sub> mm	D <sub>5</sub> mm	Flange type	Flange form		Lubrication hole [-]	Ball diameter D <sub>v</sub> mm	C <sub>am</sub> [N]	C <sub>om</sub> [N]
											L <sub>8</sub> mm	L <sub>9</sub> mm				
40	12	3	127	63	14	93	14	78	9	2	70	81,5	M8x1	7,144	50 512	99 227
	15	3	154	63	14	93	14	78	9	2	70	81,5	M8x1	7,144	50 360	98 997
50	5	4	78	75	16	110	16	93	11	2	85	97,5	M8x1	3,5	28 528	90 922
	5	5	89	75	16	110	16	93	11	2	85	97,5	M8x1	3,5	34 564	113 652
	5	6	100	75	16	110	16	93	11	2	85	97,5	M8x1	3,5	40 431	136 383
	8	3	96	75	16	110	16	93	11	2	85	97,5	M8x1	5	36 251	95 297
	8	4	112	75	16	110	16	93	11	2	85	97,5	M8x1	5	46 426	127 063
	8	5	130	75	16	110	16	93	11	2	85	97,5	M8x1	5	56 248	158 828
	10	3	114	75	16	110	16	93	11	2	85	97,5	M8x1	6,35	48 931	115 375
	10	4	134	75	16	110	16	93	11	2	85	97,5	M8x1	6,35	62 666	153 833
	10	5	157	75	16	110	16	93	11	2	85	97,5	M8x1	6,35	75 924	192 291
	12	3	132	75	16	110	16	93	11	2	85	97,5	M8x1	7,938	64 122	137 159
63	5	4	80	90	18	125	18	108	11	2	96	110	M8x1	3,5	31 656	117 528
	5	5	91	90	18	125	18	108	11	2	96	110	M8x1	3,5	38 353	146 910
	5	6	103	90	18	125	18	108	11	2	96	110	M8x1	3,5	44 864	176 292
	10	3	116	90	18	125	18	108	11	2	96	110	M8x1	6,35	54 639	148 343
	10	4	137	90	18	125	18	108	11	2	96	110	M8x1	6,35	69 976	197 791
80	10	4	141	105	20	145	20	125	13,5	2	110	127,5	M8x1	7,144	93 008	292 569
	12	4	163	105	20	145	20	125	13,5	2	110	127,5	M8x1	7,938	106 416	319 341
	20	3	219	125	25	165	25	145	13,5	2	130	147,5	M8x1	12,7	147 896	346 843

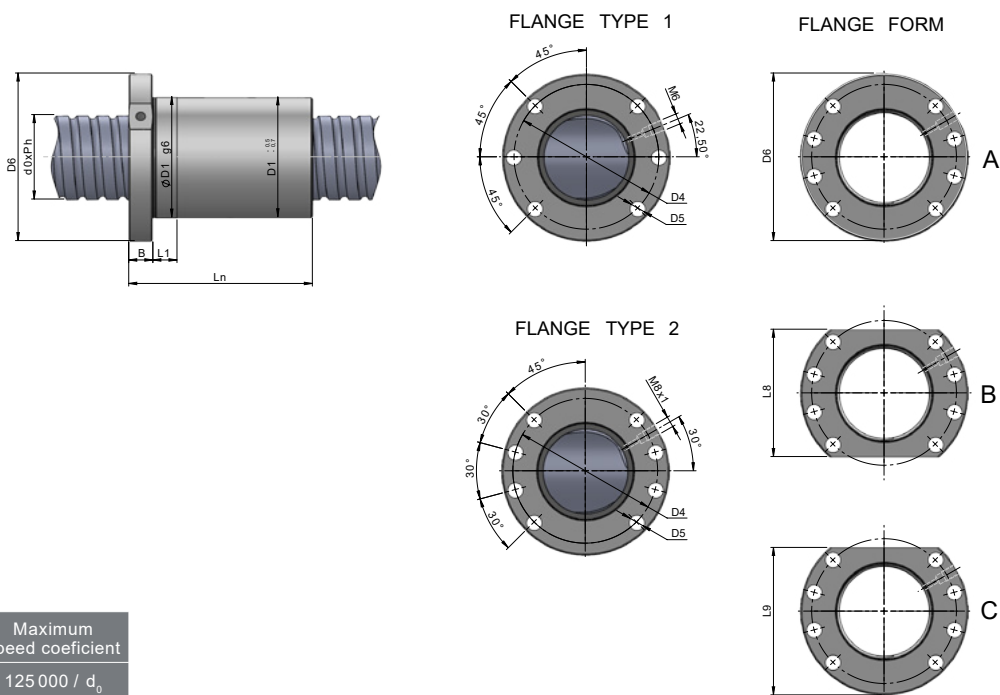

Recirculation system	Maximum speed coefficient
EX-A	125 000 / d <sub>0</sub>

Diameter d <sub>0</sub>	Pitch P <sub>h</sub> mm	Number of effective turns i	Length of the nut L <sub>n</sub> mm	Ball nut diameter D <sub>1</sub> mm	L <sub>1</sub> mm	Flange diameter D <sub>6</sub> mm	Flange width B mm	D <sub>4</sub> mm	D <sub>5</sub> mm	Flange type	Flange form		Lubrication hole [-]	Ball diameter D <sub>w</sub> mm	C <sub>am</sub> [N]	C <sub>om</sub> [N]
											L <sub>8</sub> mm	L <sub>9</sub> mm				
40	20(P10)	2,8	81	63	14	93	14	78	9	2	70	81,5	M8x1	6,35	78 846	181 312
	20(P10)	3,8	101	63	14	93	14	78	9	2	70	81,5	M8x1	6,35	102 527	246 066
	25(P12,5)	1,8	73	63	14	93	14	78	9	2	70	81,5	M8x1	6,35	53 430	115 740
	25(P12,5)	2,8	98	63	14	93	14	78	9	2	70	81,5	M8x1	6,35	78 128	180 040
	40(P20)	0,8	59	63	14	93	14	78	9	2	70	81,5	M8x1	6,35	26 495	52 579
	40(P20)	1,8	99	63	14	93	14	78	9	2	70	81,5	M8x1	6,35	53 216	118 303
	40(P20)	2,8	134	63	14	93	14	78	9	2	70	81,5	M8x1	6,35	77 815	184 027
50	30(P15)	1,8	83	75	16	110	16	93	11	2	85	97,5	M8x1	6,35	59 971	148 309
	30(P15)	2,8	113	75	16	110	16	93	11	2	85	97,5	M8x1	6,35	87 692	230 703
	30(P15)	3,8	143	75	16	110	16	93	11	2	85	97,5	M8x1	6,35	114 030	313 097
	30(P15)	1,8	83	82	16	118	16	100	11	2	100	108	M8x1	7,144	74 404	182 678
	30(P15)	5,6	113	82	16	118	16	100	11	2	100	108	M8x1	7,144	108 797	284 166
	30(P15)	7,6	143	82	16	118	16	100	11	2	100	108	M8x1	7,144	141 473	385 654
	40(P20)	1,6	63	82	16	118	16	100	11	2	100	108	M8x1	7,144	36 441	80 172
	40(P20)	3,6	103	82	16	118	16	100	11	2	100	108	M8x1	7,144	73 193	180 387
	40(P20)	5,6	143	82	16	118	16	100	11	2	100	108	M8x1	7,144	107 026	280 602
63	40(P20)	3,6	105	95	18	135	18	115	13,5	2	104	118	M8x1	7,938	93 051	250 678
	40(P20)	5,6	145	95	18	135	18	115	13,5	2	104	118	M8x1	7,938	136 063	389 944
	40(P20)	7,6	185	95	18	135	18	115	13,5	2	104	118	M8x1	7,938	176 929	529 210

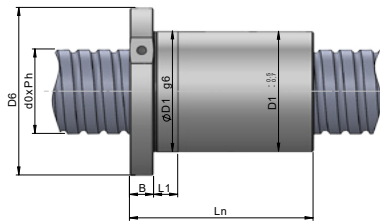

FLANGE TYPE 1

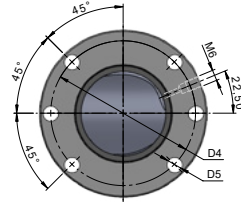

FLANGE FORM

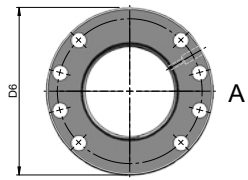

FLANGE TYPE 2

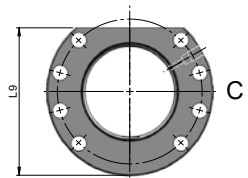
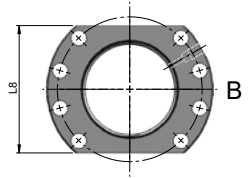
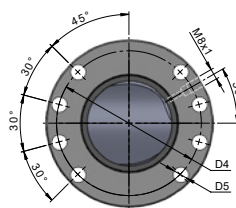

Recirculation system	Maximum speed coefficient
EX-A	125 000 / d <sub>0</sub>

Diameter d <sub>0</sub>	Pitch P <sub>n</sub> mm	Number of effective turns i	Length of the nut L <sub>n</sub> mm	Ball nut diameter D <sub>1</sub> mm	L <sub>1</sub> mm	Flange diameter D <sub>6</sub> mm	Flange width B mm	D <sub>4</sub> mm	D <sub>5</sub> mm	Flange type	Flange form		Lubrication hole [-]	Ball diameter D <sub>w</sub> mm	C <sub>am</sub> [N]	C <sub>om</sub> [N]
											L <sub>8</sub> mm	L <sub>9</sub> mm				
80	40(P20)	3,6	111	125	25	165	25	145	13,5	2	130	147,5	M8x1	10,319	147 698	410 622
	40(P20)	5,6	151	125	25	165	25	145	13,5	2	130	147,5	M8x1	10,319	215 971	638 745
	40(P20)	7,6	191	125	25	165	25	145	13,5	2	130	147,5	M8x1	10,319	280 836	866 868
	40(P20)	3,6	117	125	25	165	25	145	13,5	2	130	147,5	M8x1	12,7	190 642	485 440
	40(P20)	5,6	157	125	25	165	25	145	13,5	2	130	147,5	M8x1	12,7	278 766	755 129
	40(P20)	7,6	197	125	25	165	25	145	13,5	2	130	147,5	M8x1	12,7	362 492	1 024 818
	50(P25)	3,6	135	125	25	165	25	145	13,5	2	130	147,5	M8x1	12,7	189 064	482 346
	50(P25)	5,6	185	125	25	165	25	145	13,5	2	130	147,5	M8x1	12,7	276 459	750 315
	50(P25)	7,6	235	125	25	165	25	145	13,5	2	130	147,5	M8x1	12,7	359 491	1 018 285

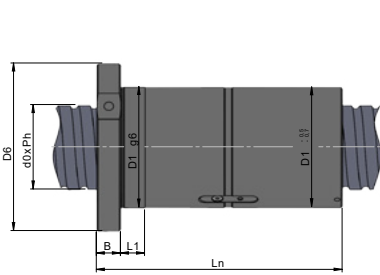

FLANGE TYPE 1

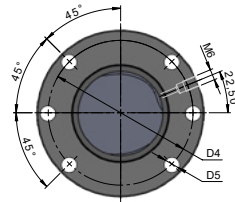

FLANGE FORM

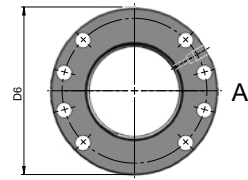

FLANGE TYPE 2

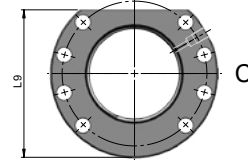
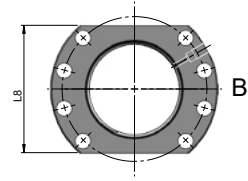
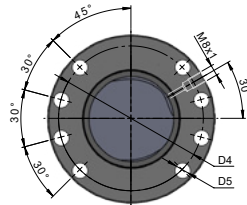

Recirculation system	Maximum speed coefficient
IN	100 000 / d <sub>0</sub>

Diameter d <sub>0</sub>	Pitch P <sub>n</sub>	Number of effective turns i	Length of the nut L <sub>n</sub>	Ball nut diameter D <sub>1</sub>	L <sub>1</sub>	Flange diameter D <sub>6</sub>	Flange width B	D <sub>4</sub>	D <sub>5</sub>	Flange type	Flange form		Lubrication hole	Ball diameter D <sub>w</sub>	C <sub>am</sub>	C <sub>om</sub>
											L <sub>8</sub>	L <sub>9</sub>				
	mm	i	mm	mm	mm	mm	mm	mm	mm	-	mm	mm	[-]	mm	[N]	[N]
20	5	3	81	36	10	58	10	47	6,6	1	44	51	M6	3,5	13 714	23 388
	5	4	89	36	10	58	10	47	6,6	1	44	51	M6	3,5	17 564	21 184
25	5	3	80	40	10	62	10	51	6,6	1	48	55	M6	3,5	16 010	31 617
	5	4	90	40	10	62	10	51	6,6	1	48	55	M6	3,5	20 504	42 156
	10	2	100	40	10	62	10	51	6,6	1	48	55	M6	3,5	11 214	20 960
	10	3	124	40	10	62	10	51	6,6	1	48	55	M6	3,5	15 893	31 440
32	5	3	83	50	12	80	12	65	9	1	62	71	M6	3,5	18 056	41 591
	5	4	91	50	12	80	12	65	9	1	62	71	M6	3,5	23 125	55 455
	5	5	102	50	12	80	12	65	9	1	62	71	M6	3,5	28 017	69 318
	5	6	113	50	12	80	12	65	9	1	62	71	M6	3,5	32 773	83 182
	6	3	92	50	12	80	12	65	9	1	62	71	M6	3,969	21 736	47 741
	6	4	104	50	12	80	12	65	9	1	62	71	M6	3,969	27 837	63 654
	6	5	115	50	12	80	12	65	9	1	62	71	M6	3,969	32 727	79 568
	8	4	122	50	12	80	12	65	9	1	62	71	M6	5	35 700	72 849
	8	5	137	50	12	80	12	65	9	1	62	71	M6	5	43 252	91 061
	10	3	136	50	12	80	12	65	9	1	62	71	M6	6,35	37 128	66 242
10	4	154	50	12	80	12	65	9	1	62	71	M6	6,35	47 549	88 323	

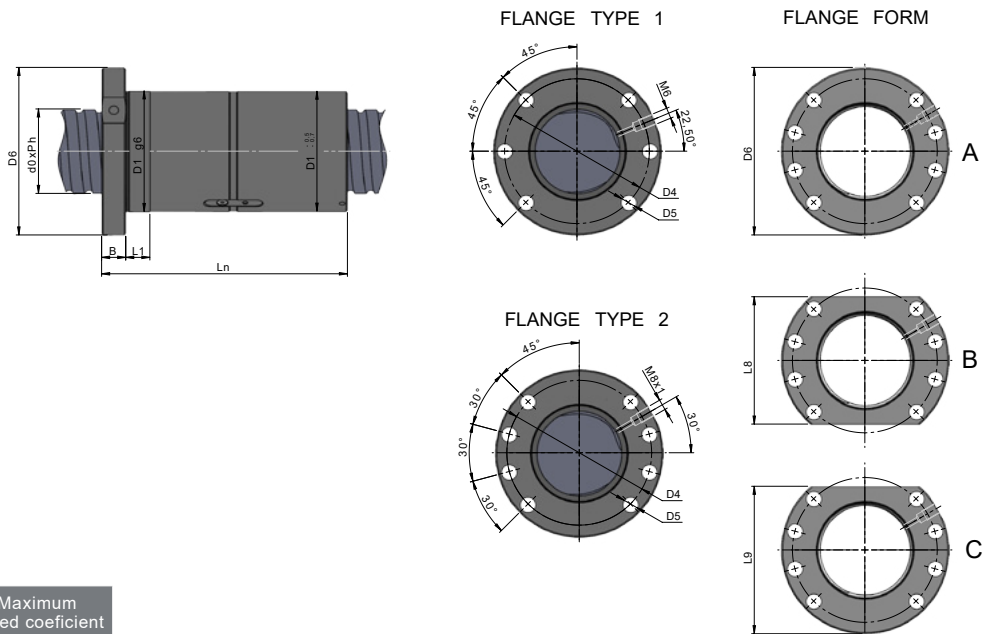

Recirculation system	Maximum speed coefficient
IN	100 000 / $d_0$

Diameter $d_0$	Pitch $P_n$	Number of effective turns $i$	Length of the nut $L_n$	Ball nut diameter $D_1$	$L_1$	Flange diameter $D_6$	Flange width $B$	$D_4$	$D_5$	Flange type	Flange form		Lubrication hole	Ball diameter $D_w$	$C_{am}$	$C_{om}$
											$L_8$	$L_9$				
	mm		mm	mm	mm	mm	mm	mm	mm	-	mm	mm	[-]	mm	[N]	[N]
32	12	3	148	50	12	80	12	65	9	1	62	71	M6	6,35	37 033	66 113
	12	4	175	50	12	80	12	65	9	1	62	71	M6	6,35	47 429	88 150
40	5	3	84	63	14	93	14	78	9	2	70	81,5	M8x1	3,5	20 106	53 229
	5	4	94	63	14	93	14	78	9	2	70	81,5	M8x1	3,5	25 750	70 973
	5	5	104	63	14	93	14	78	9	2	70	81,5	M8x1	3,5	31 197	88 716
	5	6	116	63	14	93	14	78	9	2	70	81,5	M8x1	3,5	36 493	106 459
	6	3	93	63	14	93	14	78	9	2	70	81,5	M8x1	3,969	24 157	60 777
	6	4	106	63	14	93	14	78	9	2	70	81,5	M8x1	3,969	30 937	81 037
	6	5	116	63	14	93	14	78	9	2	70	81,5	M8x1	3,969	37 482	101 296
	8	3	116	63	14	93	14	78	9	2	70	81,5	M8x1	5	31 746	71 593
	8	4	132	63	14	93	14	78	9	2	70	81,5	M8x1	5	40 657	95 457
	8	5	147	63	14	93	14	78	9	2	70	81,5	M8x1	5	49 258	119 321
	8	6	166	63	14	93	14	78	9	2	70	81,5	M8x1	5	57 620	143 185
	10	3	136	63	14	93	14	78	9	2	70	81,5	M8x1	6,35	43 004	88 036
	10	4	159	63	14	93	14	78	9	2	70	81,5	M8x1	6,35	55 075	117 381
	12	4	177	63	14	93	14	78	9	2	70	81,5	M8x1	7,144	64 691	132 303
12	5	201	63	14	93	14	78	9	2	70	81,5	M8x1	7,144	78 376	165 379	

Diameter d <sub>0</sub>	Pitch P <sub>h</sub>	Number of effective turns i	Length of the nut L <sub>n</sub>	Ball nut diameter D <sub>1</sub>	L <sub>1</sub>	Flange diameter D <sub>6</sub>	Flange width B	D <sub>4</sub>	D <sub>5</sub>	Flange type	Flange form		Lubrication hole	Ball diameter D <sub>w</sub>	C <sub>am</sub>	C <sub>om</sub>
											L <sub>8</sub>	L <sub>9</sub>				
	mm		mm	mm	mm	mm	mm	mm	mm	-	mm	mm	[-]	mm	[N]	[N]
40	15	2	144	63	14	93	14	78	9	2	70	81,5	M8x1	7,144	35 534	65 998
	15	3	181	63	14	93	14	78	9	2	70	81,5	M8x1	7,144	50 360	98 997
	15	4	213	63	14	93	14	78	9	2	70	81,5	M8x1	7,144	64 496	131 996
50	5	4	96	75	16	110	16	93	11	2	85	97,5	M8x1	3,5	28 528	90 922
	5	5	105	75	16	110	16	93	11	2	85	97,5	M8x1	3,5	34 564	113 652
	5	6	117	75	16	110	16	93	11	2	85	97,5	M8x1	3,5	40 431	136 383
	8	3	120	75	16	110	16	93	11	2	85	97,5	M8x1	5	36 251	95 297
	8	4	136	75	16	110	16	93	11	2	85	97,5	M8x1	5	46 426	127 063
	8	5	151	75	16	110	16	93	11	2	85	97,5	M8x1	5	56 248	158 828
	8	6	170	75	16	110	16	93	11	2	85	97,5	M8x1	5	65 797	190 594
	10	3	138	75	16	110	16	93	11	2	85	97,5	M8x1	6,35	48 931	115 375
	10	4	159	75	16	110	16	93	11	2	85	97,5	M8x1	6,35	62 666	153 833
	10	5	179	75	16	110	16	93	11	2	85	97,5	M8x1	6,35	75 924	192 291
	10	6	202	75	16	110	16	93	11	2	85	97,5	M8x1	6,35	88 812	230 750
	12	4	182	75	16	110	16	93	11	2	85	97,5	M8x1	7,938	82 121	182 879
	12	5	205	75	16	110	16	93	11	2	85	97,5	M8x1	7,938	99 949	228 599
	12	6	232	75	16	110	16	93	11	2	85	97,5	M8x1	7,938	116 384	274 318
	15	3	182	75	16	110	16	93	11	2	85	97,5	M8x1	7,938	63 996	136 952
	15	4	212	75	16	110	16	93	11	2	85	97,5	M8x1	7,938	81 960	182 602
20	3	217	75	16	110	16	93	11	2	85	97,5	M8x1	7,938	63 726	136 507	
20	4	263	75	16	110	16	93	11	2	85	97,5	M8x1	7,938	81 614	182 009	
63	5	4	98	90	18	125	18	108	11	2	96	110	M8x1	3,5	31 656	117 528
	5	5	108	90	18	125	18	108	11	2	96	110	M8x1	3,5	38 353	146 910
	5	6	120	90	18	125	18	108	11	2	96	110	M8x1	3,5	44 864	176 292
	10	3	143	90	18	125	18	108	11	2	96	110	M8x1	6,35	54 639	148 343
	10	4	162	90	18	125	18	108	11	2	96	110	M8x1	6,35	69 976	197 791
	10	5	183	90	18	125	18	108	11	2	96	110	M8x1	6,35	84 780	247 239
	10	6	204	90	18	125	18	108	11	2	96	110	M8x1	6,35	99 172	296 687
	12	4	190	90	18	125	18	108	11	2	96	110	M8x1	7,938	93 194	239 758
	12	5	212	90	18	125	18	108	11	2	96	110	M8x1	7,938	112 910	299 698
	12	6	240	90	18	125	18	108	11	2	96	110	M8x1	7,938	132 077	359 637
	20	3	232	95	20	135	20	115	13,5	2	104	118	M8x1	10,319	103 227	231 371
20	4	273	95	20	135	20	115	13,5	2	104	118	M8x1	10,319	132 203	308 494	
80	10	4	167	105	20	145	20	125	13,5	2	110	127,5	M8x1	7,144	93 008	292 569
	10	5	184	105	20	145	20	125	13,5	2	110	127,5	M8x1	7,144	112 781	365 712
	10	6	207	105	20	145	20	125	13,5	2	110	127,5	M8x1	7,144	131 926	438 854
	12	4	194	105	20	145	20	125	13,5	2	110	127,5	M8x1	7,938	106 416	319 341
	12	5	216	105	20	145	20	125	13,5	2	110	127,5	M8x1	7,938	128 929	399 176
	12	6	244	105	20	145	20	125	13,5	2	110	127,5	M8x1	7,938	150 815	479 011

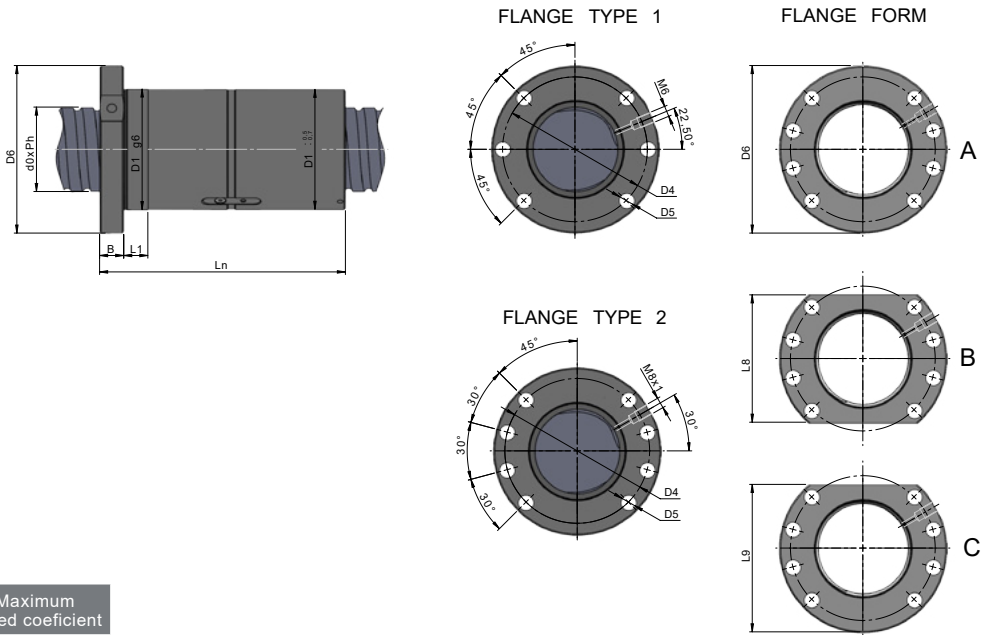

Recirculation system	Maximum speed coefficient
IN	100 000 / $d_0$

Diameter $d_0$	Pitch $P_n$	Number of effective turns $i$	Length of the nut $L_n$	Ball nut diameter $D_1$	$L_1$	Flange diameter $D_6$	Flange width $B$	$D_4$	$D_5$	Flange type	Flange form		Lubrication hole	Ball diameter $D_w$	$C_{am}$	$C_{om}$
											$L_8$	$L_9$				
	mm		mm	mm	mm	mm	mm	mm	mm	-	mm	mm	[-]	mm	[N]	[N]
80	20	3	260	125	25	165	25	145	13,5	2	130	147,5	M8x1	12,7	147 896	346 843
	20	4	304	125	25	165	25	145	13,5	2	130	147,5	M8x1	12,7	189 410	462 457
	20	5	340	125	25	165	25	145	13,5	2	130	147,5	M8x1	12,7	229 480	578 071
	20	6	388	125	25	165	25	145	13,5	2	130	147,5	M8x1	12,7	268 437	693 685
	24	3	268	125	25	165	25	145	13,5	2	130	147,5	M8x1	10,319	117 082	303 384
	24	4	319	125	25	165	25	145	13,5	2	130	147,5	M8x1	10,319	149 947	404 512
100	10	5	185	125	22	165	22	145	13,5	2	130	147,5	M8x1	7,144	125 671	471 718
	10	6	209	125	22	165	22	145	13,5	2	130	147,5	M8x1	7,144	147 005	566 062
	12	3	168	125	22	165	22	145	13,5	2	130	147,5	M8x1	7,938	92 207	307 893
	12	4	194	125	22	165	22	145	13,5	2	130	147,5	M8x1	7,938	118 089	410 524
	12	5	216	125	22	165	22	145	13,5	2	130	147,5	M8x1	7,938	143 071	513 154
	12	6	244	125	22	165	22	145	13,5	2	130	147,5	M8x1	7,938	167 359	615 785
	20	3	252	150	30	202	30	176	17,5	2	155	178,5	M8x1	12,7	168 282	454 550
	20	4	296	150	30	202	30	176	17,5	2	155	178,5	M8x1	12,7	215 519	606 066
	20	5	334	150	30	202	30	176	17,5	2	155	178,5	M8x1	12,7	261 113	757 583
	20	6	382	150	30	202	30	176	17,5	2	155	178,5	M8x1	12,7	305 438	909 099
125	20	4	304	170	30	222	30	196	17,5	2	175	198,5	M8x1	12,7	240 655	779 017
	20	5	340	170	30	222	30	196	17,5	2	175	198,5	M8x1	12,7	291 566	973 771
	20	6	386	170	30	222	30	196	17,5	2	175	198,5	M8x1	12,7	341 062	1 168 525

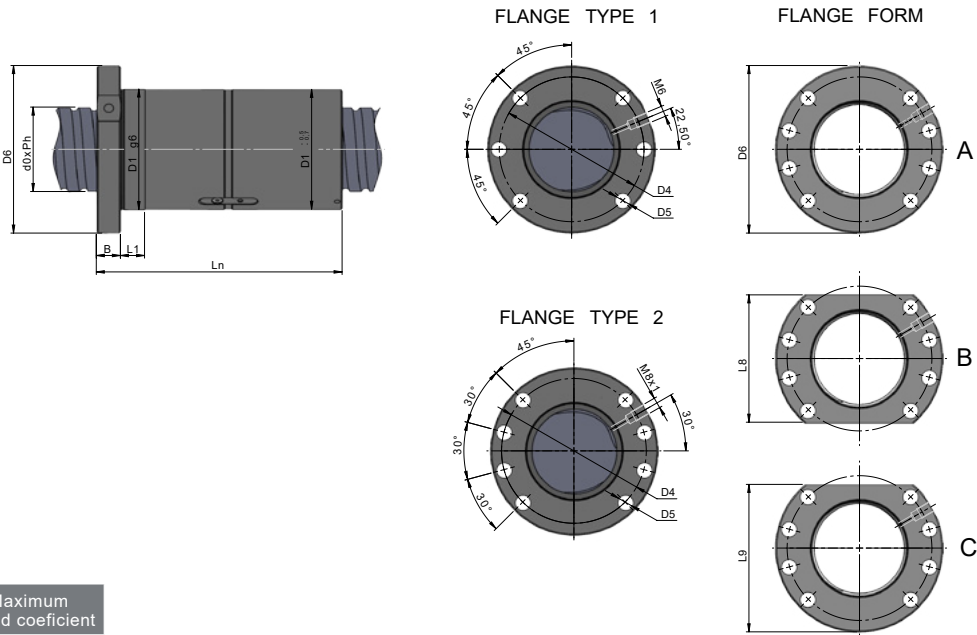

Recirculation system	Maximum speed coefficient
EX-A	125 000 / d <sub>0</sub>

Diameter d <sub>0</sub>	Pitch P <sub>n</sub>	Number of effective turns i	Length of the nut L <sub>n</sub>	Ball nut diameter D <sub>1</sub>	L <sub>1</sub>	Flange diameter D <sub>6</sub>	Flange width B	D <sub>4</sub>	D <sub>5</sub>	Flange type	Flange form		Lubrication hole	Ball diameter D <sub>w</sub>	C <sub>am</sub>	C <sub>om</sub>
											L <sub>3</sub>	L <sub>9</sub>				
	mm	i	mm	mm	mm	mm	mm	mm	mm	-	mm	mm	[-]	mm	[N]	[N]
40	20	2,8	169	63	14	93	14	78	9	2	70	81,5	M8X1	6,35	43 440	90 656
	20	3,8	209	63	14	93	14	78	9	2	70	81,5	M8X1	6,35	56 487	123 033
	20(P10)	5,6	169	63	14	93	14	78	9	2	70	81,5	M8X1	6,35	78 846	181 312
	20(P10)	7,6	209	63	14	93	14	78	9	2	70	81,5	M8X1	6,35	102 527	246 066
	25	1,8	150	63	14	93	14	78	9	2	70	81,5	M8X1	6,35	29 437	57 870
	25	2,8	200	63	14	93	14	78	9	2	70	81,5	M8X1	6,35	43 045	90 020
	25(P12,5)	3,6	150	63	14	93	14	78	9	2	70	81,5	M8X1	6,35	53 430	115 740
	25(P12,5)	5,6	200	63	14	93	14	78	9	2	70	81,5	M8X1	6,35	78 128	180 040
	40	0,8	126	63	14	93	14	78	9	2	70	81,5	M8X1	6,35	14 598	26 290
	40	1,8	206	63	14	93	14	78	9	2	70	81,5	M8X1	6,35	29 319	59 151
	40	2,8	286	63	14	93	14	78	9	2	70	81,5	M8X1	6,35	42 872	92 013
	40(P20)	1,6	126	63	14	93	14	78	9	2	70	81,5	M8X1	6,35	26 495	52 579
40(P20)	3,6	206	63	14	93	14	78	9	2	70	81,5	M8X1	6,35	53 216	118 303	
40(P20)	5,6	286	63	14	93	14	78	9	2	70	81,5	M8X1	6,35	77 815	184 027	
50	30	1,8	173	75	16	110	16	93	11	2	85	97,5	M8X1	6,35	33 041	74 154
	30	2,8	233	75	16	110	16	93	11	2	85	97,5	M8X1	6,35	48 314	115 351
	30	3,8	293	75	16	110	16	93	11	2	85	97,5	M8X1	6,35	62 825	156 548
	30(P15)	3,6	173	75	16	110	16	93	11	2	85	97,5	M8X1	6,35	59 971	148 309
	30(P15)	5,6	233	75	16	110	16	93	11	2	85	97,5	M8X1	6,35	87 692	230 703
	30(P15)	7,6	293	75	16	110	16	93	11	2	85	97,5	M8X1	6,35	114 030	313 097

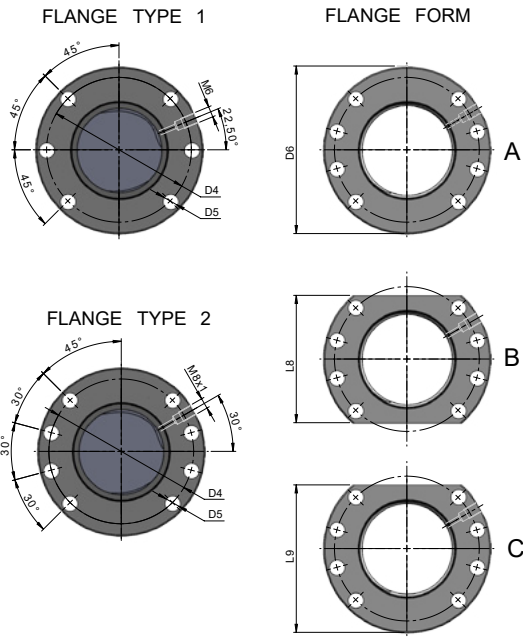
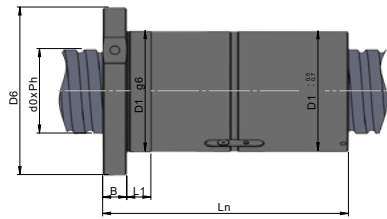

Recirculation system	Maximum speed coefficient
EX-A	125 000 / d <sub>0</sub>

Diameter d <sub>0</sub>	Pitch P <sub>h</sub>	Number of effective turns i	Length of the nut L <sub>n</sub>	Ball nut diameter D <sub>1</sub>	L <sub>1</sub>	Flange diameter D <sub>6</sub>	Flange width B	D <sub>4</sub>	D <sub>5</sub>	Flange type	Flange form		Lubrication hole	Ball diameter D <sub>w</sub>	C <sub>em</sub>	C <sub>cm</sub>
											L <sub>8</sub>	L <sub>9</sub>				
	mm	i	mm	mm	mm	mm	mm	mm	mm	-	mm	mm	[-]	mm	[N]	[N]
50	30	1,8	173	82	16	118	16	100	11	2	100	108	M8X1	7,144	40 993	91 339
	30	2,8	233	82	16	118	16	100	11	2	100	108	M8X1	7,144	59 942	142 083
	30	3,8	293	82	16	118	16	100	11	2	100	108	M8X1	7,144	77 945	192 827
	30(P15)	3,6	173	82	16	118	16	100	11	2	100	108	M8X1	7,144	74 404	182 678
	30(P15)	5,6	233	82	16	118	16	100	11	2	100	108	M8X1	7,144	108 797	284 166
	30(P15)	7,6	293	82	16	118	16	100	11	2	100	108	M8X1	7,144	141 473	385 654
	40	0,8	130	82	16	118	16	100	11	2	100	108	M8X1	7,144	20 077	40 086
	40	1,8	210	82	16	118	16	100	11	2	100	108	M8X1	7,144	40 326	90 194
	40	2,8	290	82	16	118	16	100	11	2	100	108	M8X1	7,144	58 966	140 301
	40(P20)	1,6	130	82	16	118	16	100	11	2	100	108	M8X1	7,144	36 441	80 172
	40(P20)	3,6	210	82	16	118	16	100	11	2	100	108	M8X1	7,144	73 193	180 387
40(P20)	5,6	290	82	16	118	16	100	11	2	100	108	M8X1	7,144	107 026	280 602	
63	30	2,8	236	95	18	135	18	115	13,5	2	104	118	M8X1	7,938	73 810	189 012
	30	3,8	296	95	18	135	18	115	13,5	2	104	118	M8X1	7,938	95 978	256 516
	30	4,8	356	95	18	135	18	115	13,5	2	104	118	M8X1	7,938	117 335	324 020
	30	2,8	251	105	20	145	20	125	13,5	2	110	127,5	M8X1	10,319	107 599	252 586
	30	3,8	311	105	20	145	20	125	13,5	2	110	127,5	M8X1	10,319	139 915	242 795
	30	4,8	371	105	20	145	20	125	13,5	2	110	127,5	M8X1	10,319	171 048	433 004
	40	1,8	215	95	18	135	18	115	13,5	2	104	118	M8X1	7,938	51 267	125 339
	40	2,8	295	95	18	135	18	115	13,5	2	104	118	M8X1	7,938	74 965	194 972
	40	3,8	375	95	18	135	18	115	13,5	2	104	118	M8X1	7,938	97 480	264 605
	40(P20)	3,6	215	95	18	135	18	115	13,5	2	104	118	M8X1	7,938	93 051	250 678
	40(P20)	5,6	295	95	18	135	18	115	13,5	2	104	118	M8X1	7,938	136 063	389 944
	40(P20)	7,6	375	95	18	135	18	115	13,5	2	104	118	M8X1	7,938	176 929	529 210

Diameter d <sub>0</sub>	Pitch P <sub>h</sub>	Number of effective turns i	Length of the nut L <sub>n</sub>	Ball nut diameter D <sub>1</sub>	L <sub>1</sub>	Flange diameter D <sub>6</sub>	Flange width B	D <sub>4</sub>	D <sub>5</sub>	Flange type	Flange form		Lubrication hole	Ball diameter D <sub>w</sub>	C <sub>am</sub>	C <sub>om</sub>
											L <sub>3</sub>	L <sub>3</sub>				
	mm	mm	mm	mm	mm	mm	mm	mm	mm	mm	-	mm	mm	[-]	mm	[N]
63	40	1,8	228	105	20	145	20	125	13,5	2	110	127,5	M8X1	10,319	72 822	161 082
	40	2,8	308	105	20	145	20	125	13,5	2	110	127,5	M8X1	10,319	106 485	250 572
	40	3,8	388	105	20	145	20	125	13,5	2	110	127,5	M8X1	10,319	138 467	340 062
80	16	2,8	167	125	25	165	25	145	13,5	2	130	147,5	M8X1	10,319	120 522	322 532
	16	3,8	199	125	25	165	25	145	13,5	2	130	147,5	M8X1	10,319	156 720	437 722
	16	4,8	231	125	25	165	25	145	13,5	2	130	147,5	M8X1	10,319	191 593	522 912
	16	5,8	263	125	25	165	25	145	13,5	2	130	147,5	M8X1	10,319	225 455	668 102
	20	2,8	190	125	25	165	25	145	13,5	2	130	147,5	M8X1	10,319	120 356	322 189
	20	3,8	230	125	25	165	25	145	13,5	2	130	147,5	M8X1	10,319	156 504	437 256
	20	4,8	270	125	25	165	25	145	13,5	2	130	147,5	M8X1	10,319	191 328	552 324
	20	5,8	310	125	25	165	25	145	13,5	2	130	147,5	M8X1	10,319	225 143	667 391
	25	2,8	232	125	25	165	25	145	13,5	2	130	147,5	M8X1	10,319	120 097	321 655
	25	3,8	282	125	25	165	25	145	13,5	2	130	147,5	M8X1	10,319	156 167	436 532
	25	4,8	332	125	25	165	25	145	13,5	2	130	147,5	M8X1	10,319	190 916	551 409
	25	2,8	231	125	25	165	25	145	13,5	2	130	147,5	M8X1	12,7	154 995	380 225
	25	3,8	281	125	25	165	25	145	13,5	2	130	147,5	M8X1	12,7	201 547	516 019
	25	4,8	331	125	25	165	25	145	13,5	2	130	147,5	M8X1	12,7	246 394	651 814
	30	2,8	261	125	25	165	25	145	13,5	2	130	147,5	M8X1	10,319	119 782	321 006
	30	3,8	321	125	25	165	25	145	13,5	2	130	147,5	M8X1	10,319	155 757	435 651
	30	4,8	381	125	25	165	25	145	13,5	2	130	147,5	M8X1	10,319	190 415	550 297
	30	5,8	441	125	25	165	25	145	13,5	2	130	147,5	M8X1	10,319	224 069	664 942
	30	2,8	264	125	25	165	25	145	13,5	2	130	147,5	M8X1	12,7	154 595	379 469
	30	3,8	324	125	25	165	25	145	13,5	2	130	147,5	M8X1	12,7	201 026	514 993
	30	4,8	384	125	25	165	25	145	13,5	2	130	147,5	M8X1	12,7	245 757	650 518
	30	5,8	444	125	25	165	25	145	13,5	2	130	147,5	M8X1	12,7	289 193	786 043
	40	1,8	231	125	25	165	25	145	13,5	2	130	147,5	M8X1	10,319	81 374	205 311
	40	2,8	311	125	25	165	25	145	13,5	2	130	147,5	M8X1	10,319	118 990	319 372
	40	3,8	391	125	25	165	25	145	13,5	2	130	147,5	M8X1	10,319	154 727	433 434
	40(P20)	3,6	231	125	25	165	25	145	13,5	2	130	147,5	M8X1	10,319	147 698	410 622
	40(P20)	5,6	311	125	25	165	25	145	13,5	2	130	147,5	M8X1	10,319	215 971	638 745
	40(P20)	7,6	391	125	25	165	25	145	13,5	2	130	147,5	M8X1	10,319	280 836	866 868
	40	1,8	240	125	25	165	25	145	13,5	2	130	147,5	M8X1	12,7	105 035	242 720
	40	2,8	320	125	25	165	25	145	13,5	2	130	147,5	M8X1	12,7	153 587	377 565
	40	3,8	400	125	25	165	25	145	13,5	2	130	147,5	M8X1	12,7	199 716	512 409
	40(P20)	3,6	240	125	25	165	25	145	13,5	2	130	147,5	M8X1	12,7	190 642	485 440
	40(P20)	5,6	320	125	25	165	25	145	13,5	2	130	147,5	M8X1	12,7	278 766	755 129
	40(P20)	7,6	400	125	25	165	25	145	13,5	2	130	147,5	M8X1	12,7	362 492	1 024 818
	50	1,8	278	125	25	165	25	145	13,5	2	130	147,5	M8X1	12,7	104 165	241 173
	50	2,8	378	125	25	165	25	145	13,5	2	130	147,5	M8X1	12,7	152 316	375 158
50	3,8	478	125	25	165	25	145	13,5	2	130	147,5	M8X1	12,7	198 062	509 143	
50(P25)	3,6	278	125	25	165	25	145	13,5	2	130	147,5	M8X1	12,7	189 064	482 346	
50(P25)	5,6	378	125	25	165	25	145	13,5	2	130	147,5	M8X1	12,7	276 459	750 315	
50(P25)	7,6	478	125	25	165	25	145	13,5	2	130	147,5	M8X1	12,7	359 491	1 018 285	

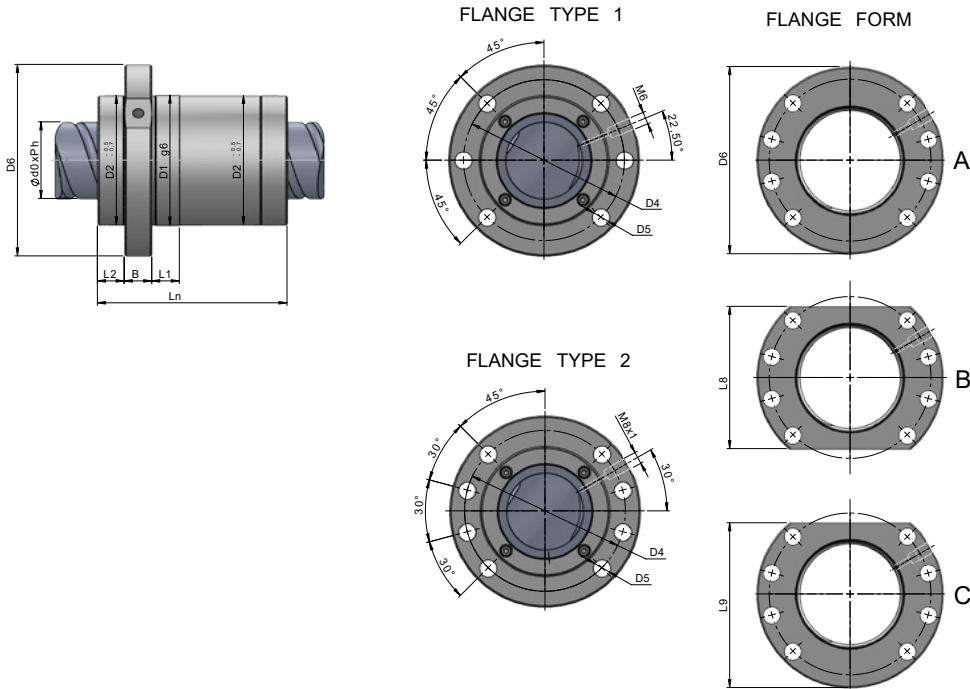

Recirculation system	Maximum speed coefficient
IN	100 000 / $d_0$

Diameter $d_0$	Pitch $P_h$ mm	Number of effective turns $i$	Length of the nut $L_n$ mm	Ball nut diameter $D_1$ mm	$L_1$ mm	Flange diameter $D_6$ mm	Flange width $B$ mm	$L_2$ mm	$D_4$ mm	$D_5$ mm	Flange type	Flange form		Lubrication hole [-]	Ball diameter $D_w$ mm	$C_{am}$ [N]	$C_{om}$ [N]
												$L_3$ mm	$L_9$ mm				
20	20(P10)	3,6	55	36	10	58	10	11	47	6,6	1	44	51	M6	3,5	17 800	34 100
25	20(P10)	3,6	52,5	40	10	62	10	10	51	6,6	1	48	55	M6	3,5	19 800	42 450
	25(P12,5)	3,6	62,5	40	10	62	10	10	51	6,6	1	48	55	M6	3,5	20 000	43 600
32	25(P12,5)	5,6	90	51	12	80	12	12	64	9	1	62	71	M6	3,969	39 000	98 000
	32(P16)	5,6	110	51	12	80	12	12	64	9	1	62	71	M6	3,969	39 000	100 000
40	40(20)	3,6	104	75	16	110	16	18,5	93	9	2	85	97,5	M8x1	7,938	73 500	155 600
50	40(P20)	5,6	144	85	18	125	18	17,5	105	11	2	95	110	M8x1	7,938	122 000	308 000
	50(P25)	3,6	124	85	18	125	18	17,5	105	11	2	95	110	M8x1	7,938	81 700	195 000

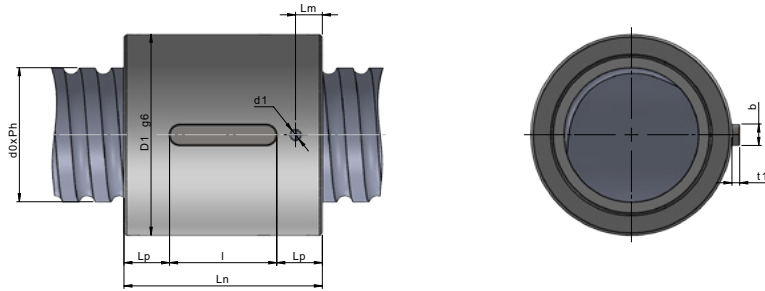

Recirculation system	Maximum speed coefficient
IN	100 000 / d <sub>0</sub>

Diameter d <sub>0</sub>	Pitch P <sub>n</sub>	Number of effective turns i	Length of the nut L <sub>n</sub>	Ball nut diameter D <sub>1</sub>	Lubrication hole d <sub>1</sub>	L <sub>m</sub>	L <sub>p</sub>	b	l	t <sub>1</sub>	Ball diameter D <sub>w</sub>	C <sub>am</sub>	C <sub>am</sub>
	mm	i	mm	mm	mm	mm	mm	mm	-	mm	mm	[N]	[N]
25	5	3	35	40	∅3	7	9,5	5	16	2,1	3,5	16 010	31 617
	5	4	41	40	∅3	7	10,5	5	20	2,1	3,5	20 504	42 156
	10	2	45	40	∅3	8	12,5	5	20	2,1	3,5	11 214	20 960
	10	3	57	40	∅3	8	16	5	25	2,1	3,5	15 893	31 440
32	5	4	41	50	∅4	8	11,5	8	18	2,9	3,5	23 125	55 455
	5	5	46	50	∅4	8	13	8	20	2,9	3,5	28 017	69 318
	5	6	52	50	∅4	8	16	8	20	2,9	3,5	32 773	83 182
	6	3	40	50	∅3	8	11	8	18	2,9	3,969	21 736	47 741
	6	4	47	50	∅3	8	13,5	8	20	2,9	3,969	27 837	63 654
	6	5	52	50	∅3	8	13,5	8	25	2,9	3,969	32 727	79 568

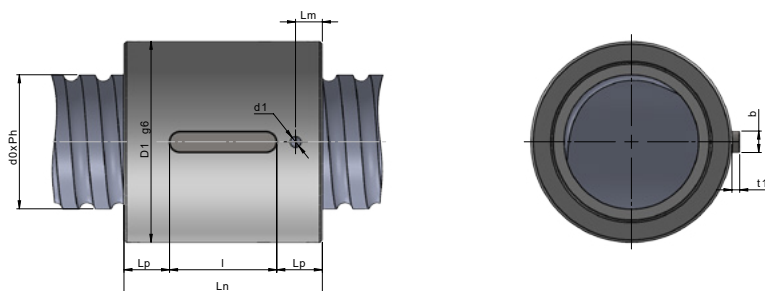

Recirculation system	Maximum speed coefficient
IN	100 000 / $d_0$

Diameter $d_0$	Pitch $P_h$	Number of effective turns $i$	Length of the nut $L_n$	Ball nut diameter $D_1$	Lubrication hole $d_1$	$L_m$	$L_p$	$b$	$l$	$t_1$	Ball diameter $D_w$	$C_{sm}$	$C_{om}$
	mm	$i$	mm	mm	mm	mm	mm	mm	-	mm	mm	[N]	[N]
32	8	4	60	50	ø4	8,5	16	8	28	2,9	5	35 700	72 849
	8	5	67	50	ø4	9	17,5	8	32	2,9	5	43 252	91 061
	10	3	63	50	ø4	10	15,5	8	32	2,9	6,35	37 128	66 242
	12	3	72	50	ø4	10	20	8	32	2,9	6,35	37 033	66 113
40	5	4	41	63	ø4	8	11,5	8	18	2,9	3,5	25 750	70 973
	5	5	46	63	ø4	8	13	8	20	2,9	3,5	31 197	88 716
	5	6	52	63	ø4	8	13,5	8	25	2,9	3,5	36 493	106 459
	6	3	40	63	ø4	8	11	8	18	2,9	3,969	24 157	60 777
	6	4	46	63	ø4	8	13	8	20	2,9	3,969	30 937	81 037
	6	5	52	63	ø4	8	13,5	8	25	2,9	3,969	37 482	101 296
	8	3	52	63	ø4	9	13,5	8	25	2,9	5	31 746	71 593
	8	4	60	63	ø4	9	14	8	32	2,9	5	40 657	95 457
	8	5	68	63	ø4	9	18	8	32	2,9	5	49 258	119 321
	8	6	77	63	ø4	9	22,5	8	32	2,9	5	57 620	143 185
	10	3	63	63	ø4	10	17,5	8	28	2,9	6,35	43 004	88 036
	10	4	74	63	ø4	10	21	8	32	2,9	6,35	55 075	117 381
	15	2	67	63	ø4	10	19,5	8	28	2,9	7,144	35 534	65 998
	15	3	85	63	ø4	10	26,5	8	32	2,9	7,144	50 360	98 997
15	4	101	63	ø4	10	30,5	8	40	2,9	7,144	64 496	131 996	

Diameter $d_0$	Pitch $P_i$	Number of effective turns $i$	Length of the nut $L_n$	Ball nut diameter $D_1$	Lubricati- on hole $d_1$	$L_m$	$L_p$	$b$	$l$	$t_1$	Ball diameter $D_w$	$C_{am}$	$C_{om}$
	mm	$i$	mm	mm	mm	mm	mm	mm	-		mm	[N]	[N]
50	5	4	41	75	ø4	8	11,5	8	18	2,9	3,5	28 528	90 922
	5	5	46	75	ø4	8	13	8	20	2,9	3,5	34 564	113 652
	5	6	51	75	ø4	8	13	8	25	2,9	3,5	40 431	136 383
	8	3	53	75	ø4	9	14	8	25	2,9	5	36 251	95 297
	8	4	61	75	ø4	9	16,5	8	28	2,9	5	46 426	127 063
	8	5	69	75	ø4	9	20,5	8	28	2,9	5	56 248	158 828
	8	6	78	75	ø4	9	23	8	32	2,9	5	65 797	190 594
	10	3	63	75	ø4	10	15,5	8	32	2,9	6,35	48 931	115 375
	10	4	74	75	ø4	10	17	8	40	2,9	6,35	62 666	153 833
	10	5	83	75	ø4	10	21,5	8	40	2,9	6,35	75 924	192 291
	10	6	94	75	ø4	10	27	8	40	2,9	6,35	88 812	230 750
	12	4	84	75	ø4	11	22	10	40	3,3	7,938	82 121	182 879
	12	5	95	75	ø4	11	25	10	45	3,3	7,938	99 949	228 599
	12	6	110	75	ø4	11	32	10	45	3,3	7,938	116 384	274 318
	15	3	84	75	ø4	11	26	8	32	2,9	7,938	63 996	136 952
	15	4	100	75	ø4	11	30	8	40	2,9	7,938	81 960	182 602
	20	3	103	75	ø4	11	31,5	8	40	2,9	7,938	63 726	136 507
20	4	125	75	ø4	11	42,5	8	40	2,9	7,938	81 614	182 009	
63	10	3	63	90	ø5	11	19	10	25	3,3	6,35	54 639	148 343
	10	4	74	90	ø5	11	21	10	32	3,3	6,35	69 976	197 791
	10	5	83	90	ø5	11	25,5	10	32	3,3	6,35	84 780	247 239
	10	6	95	90	ø5	11	27,5	10	40	3,3	6,35	99 172	296 687
	12	4	88	90	ø5	11	24	10	40	3,3	7,938	93 194	239 758
	12	5	99	90	ø5	11	29,5	10	40	3,3	7,938	112 910	299 698
	12	6	113	90	ø5	11	34	10	45	3,3	7,938	132 077	359 637
	20	3	112	95	ø5	14	33,5	10	45	3,3	10,319	103 227	231 371
20	4	134	95	ø5	14	32	10	70	3,3	10,319	132 203	308 494	
80	10	4	76	105	ø5	14	21,5	12	32	3,1	7,144	93 008	292 569
	10	5	85	105	ø5	14	22,5	12	40	3,1	7,144	112 781	365 712
	10	6	96	105	ø5	14	28	12	40	3,1	7,144	131 926	438 854
	12	4	89	105	ø5	14	24,5	12	40	3,1	7,938	106 416	319 341
	12	5	100	105	ø5	14	30	12	40	3,1	7,938	128 929	399 176
	12	6	114	105	ø5	14	29	12	56	3,1	7,938	150 815	479 011
	20	3	120	125	ø5	14	25	14	70	3,5	12,7	147 896	346 843
	20	4	142	125	ø5	14	32	14	70	3,5	12,7	189 410	462 457
	20	5	160	125	ø5	14	45	14	70	3,5	12,7	229 480	578 071
	20	6	184	125	ø5	14	57	14	70	3,5	12,7	268 437	693 685

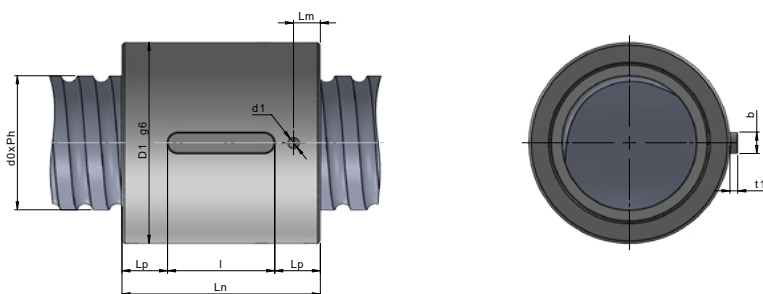

Recirculation system	Maximum speed coefficient
EX-A	125 000 / d <sub>0</sub>

Diameter d <sub>0</sub>	Pitch P <sub>n</sub>	Number of effective turns i	Length of the nut L <sub>n</sub>	Ball nut diameter D <sub>1</sub>	Lubrication hole d <sub>1</sub>	L <sub>m</sub>	L <sub>p</sub>	b	l	t <sub>1</sub>	Ball diameter D <sub>w</sub>	C <sub>am</sub>	C <sub>om</sub>
	mm	i	mm	mm	mm	mm	mm	mm	-	mm	mm	[N]	[N]
40	20	2,8	81	63	∅4	10	24,5	8	32	2,5	6,35	43 440	90 656
	20	3,8	101	63	∅4	10	30,5	8	40	2,5	6,35	56 487	123 033
	20(P10)	5,6	81	63	∅4	10	24,5	8	32	2,5	6,35	78 846	181 312
	20(P10)	7,6	101	63	∅4	10	30,5	8	40	2,5	6,35	102 527	246 066
	25	1,8	73	63	∅4	10	20,5	8	32	2,5	6,35	29 437	57 870
	25	2,8	98	63	∅4	10	29	8	40	2,5	6,35	43 045	90 020
	25(P12,5)	3,6	73	63	∅4	10	20,5	8	32	2,5	6,35	53 430	115 740
	25(P12,5)	5,6	98	63	∅4	10	29	8	40	2,5	6,35	78 128	180 040
	40	0,8	59	63	∅4	10	17	8	25	2,5	6,35	14 598	26 290
	40	1,8	99	63	∅4	10	29,5	8	40	2,5	6,35	29 319	59 151
	40	2,8	134	63	∅4	10	47	8	40	2,5	6,35	42 872	92 013
	40(P20)	1,6	59	63	∅4	10	17	8	25	2,5	6,35	26 495	52 579
	40(P20)	3,6	99	63	∅4	10	29,5	8	40	2,5	6,35	53 216	118 303
	40(P20)	5,6	134	63	∅4	10	47	8	40	2,5	6,35	77 815	184 027
50	30	1,8	83	75	∅4	10	21,5	8	40	2,5	6,35	33 041	74 154
	30	2,8	113	75	∅4	10	36,5	8	40	2,5	6,35	48 314	115 351
	30	3,8	143	75	∅4	10	51,5	8	40	2,5	6,35	62 825	156 548
	30(P15)	3,6	83	75	∅4	10	25,5	8	32	2,5	6,35	59 971	148 309
	30(P15)	5,6	113	75	∅4	10	36,5	8	40	2,5	6,35	87 692	230 703
	30(P15)	7,6	143	75	∅4	10	51,5	8	40	2,5	6,35	114 030	313 097
	30	1,8	83	82	∅4	10	25,5	8	32	2,5	7,144	40 993	91 339
	30	2,8	113	82	∅4	10	36,5	8	40	2,5	7,144	59 942	142 083
	30	3,8	143	82	∅4	10	51,5	8	40	2,5	7,144	77 945	192 827

Diameter d <sub>0</sub>	Pitch P <sub>h</sub>	Number of effective turns i	Length of the nut L <sub>n</sub>	Ball nut diameter D <sub>i</sub>	Lubricati- on hole d <sub>1</sub>	L <sub>m</sub>	L <sub>p</sub>	b	l	t <sub>i</sub>	Ball diameter D <sub>w</sub>	C <sub>am</sub>	C <sub>om</sub>
	mm	i	mm	mm	mm	mm	mm	mm	-		mm	[N]	[N]
50	30(P15)	3,6	83	82	ø4	10	25,5	8	32	2,5	7,144	74 404	182 678
	30(P15)	5,6	113	82	ø4	10	36,5	8	40	2,5	7,144	108 797	284 166
	30(P15)	7,6	143	82	ø4	10	51,5	8	40	2,5	7,144	141 473	385 654
	40	0,8	63	82	ø4	10	17,5	8	28	2,5	7,144	20 077	40 086
	40	1,8	103	82	ø4	10	31,5	8	40	2,5	7,144	40 326	90 194
	40	2,8	143	82	ø4	10	51,5	8	40	2,5	7,144	58 966	140 301
	40(P20)	1,6	63	82	ø4	10	17,5	8	28	2,5	7,144	36 441	80 172
	40(P20)	3,6	103	82	ø4	10	31,5	8	40	2,5	7,144	73 193	180 387
40(P20)	5,6	143	82	ø4	10	51,5	8	40	2,5	7,144	107 026	280 602	
63	30	2,8	115	95	ø5	12	35	10	45	3,5	7,938	73 810	189 012
	30	3,8	145	95	ø5	12	50	10	45	3,5	7,938	95 978	256 516
	30	4,8	175	95	ø5	12	65	10	45	3,5	7,938	117 335	324 020
	30	2,8	124	105	ø5	14	34	14	56	3,5	10,319	107 599	252 586
	30	3,8	154	105	ø5	14	49	14	56	3,5	10,319	139 915	242 795
	30	4,8	184	105	ø5	14	64	14	56	3,5	10,319	171 048	433 004
	40	1,8	105	95	ø5	12	30	10	45	3,5	7,938	51 267	125 339
	40	2,8	145	95	ø5	12	50	10	45	3,5	7,938	74 965	194 972
	40	3,8	185	95	ø5	12	70	10	45	3,5	7,938	97 480	264 605
	40(P20)	3,6	105	95	ø5	12	30	10	45	3,5	7,938	93 051	250 678
	40(P20)	5,6	145	95	ø5	12	50	10	45	3,5	7,938	136 063	389 944
	40(P20)	7,6	185	95	ø5	12	70	10	45	3,5	7,938	176 929	529 210
	40	1,8	112	105	ø5	14	28	14	56	3,5	10,319	72 822	161 082
	40	2,8	152	105	ø5	14	48	14	56	3,5	10,319	106 485	250 572
40	3,8	192	105	ø5	14	68	14	56	3,5	10,319	138 467	340 062	
80	16	2,8	82	125	ø5	14	13	14	56	3,5	10,319	120 522	322 532
	16	3,8	98	125	ø5	14	21	14	56	3,5	10,319	156 720	437 722
	16	4,8	114	125	ø5	14	29	14	56	3,5	10,319	191 593	522 912
	16	5,8	130	125	ø5	14	37	14	56	3,5	10,319	225 455	668 102
	20	2,8	93	125	ø5	14	18,5	14	56	3,5	10,319	120 356	322 189
	20	3,8	113	125	ø5	14	28,5	14	56	3,5	10,319	156 504	437 256
	20	4,8	133	125	ø5	14	38,5	14	56	3,5	10,319	191 328	552 324
	20	5,8	153	125	ø5	14	48,5	14	56	3,5	10,319	225 143	667 391
	25	2,8	113	125	ø5	14	28,5	14	56	3,5	10,319	120 097	321 655
	25	3,8	138	125	ø5	14	41	14	56	3,5	10,319	156 167	436 532
	25	4,8	163	125	ø5	14	53,5	14	56	3,5	10,319	190 916	551 409
	25	2,8	113	125	ø5	14	28,5	14	56	3,5	12,7	154 995	380 225
	25	3,8	138	125	ø5	14	41	14	56	3,5	12,7	201 547	516 019
	25	4,8	163	125	ø5	14	46,5	14	70	3,5	12,7	246 394	651 814

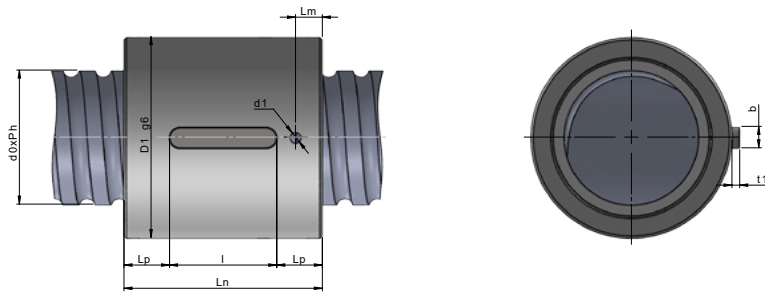

Recirculation system	Maximum speed coefficient
EX-A	125 000 / d <sub>0</sub>

Diameter d <sub>0</sub>	Pitch P <sub>h</sub>	Number of effective turns i	Length of the nut L <sub>n</sub>	Ball nut diameter D <sub>1</sub>	Lubrication hole d <sub>1</sub>	L <sub>m</sub>	L <sub>p</sub>	b	l	t <sub>1</sub>	Ball diameter D <sub>w</sub>	C <sub>am</sub>	C <sub>om</sub>
	mm	i	mm	mm	mm	mm	mm	mm	-	mm	mm	[N]	[N]
80	30	2,8	126	125	∅5	14	28	14	70	3,5	10,319	119 782	321 006
	30	3,8	156	125	∅5	14	43	14	70	3,5	10,319	155 757	435 651
	30	4,8	186	125	∅5	14	58	14	70	3,5	10,319	190 415	550 297
	30	5,8	216	125	∅5	14	73	14	70	3,5	10,319	224 069	664 942
	30	2,8	129	125	∅5	14	29,5	14	70	3,5	12,7	154 595	379 469
	30	3,8	159	125	∅5	14	44,5	14	70	3,5	12,7	201 026	514 993
	30	4,8	189	125	∅5	14	59,5	14	70	3,5	12,7	245 757	650 518
	30	5,8	219	125	∅5	14	74,5	14	70	3,5	12,7	289 193	786 043
	40	1,8	111	125	∅5	14	20,5	14	70	3,5	10,319	81 374	205 311
	40	2,8	151	125	∅5	14	40,5	14	70	3,5	10,319	118 990	319 372
	40	3,8	191	125	∅5	14	60,5	14	70	3,5	10,319	154 727	433 434
	40(P20)	3,6	111	125	∅5	14	20,5	14	70	3,5	10,319	147 698	410 622
	40(P20)	5,6	151	125	∅5	14	40,5	14	70	3,5	10,319	215 971	638 745
	40(P20)	7,6	191	125	∅5	14	60,5	14	70	3,5	10,319	280 836	866 868
	40	1,8	117	125	∅5	14	23,5	14	70	3,5	12,7	105 035	242 720
	40	2,8	157	125	∅5	14	43,5	14	70	3,5	12,7	153 587	377 565
	40	3,8	197	125	∅5	14	63,5	14	70	3,5	12,7	199 716	512 409
	40(P20)	3,6	117	125	∅5	14	23,5	14	70	3,5	12,7	190 642	485 440
	40(P20)	5,6	157	125	∅5	14	43,5	14	70	3,5	12,7	278 766	755 129
	40(P20)	7,6	197	125	∅5	14	63,5	14	70	3,5	12,7	362 492	1 024 818
	50	1,8	135	125	∅5	14	32,5	14	70	3,5	12,7	104 165	241 173
	50	2,8	185	125	∅5	14	57,5	14	70	3,5	12,7	152 316	375 158
	50	3,8	235	125	∅5	14	82,5	14	70	3,5	12,7	198 062	509 143
	50(P25)	3,6	135	125	∅5	14	32,5	14	70	3,5	12,7	189 064	482 346
	50(P25)	5,6	185	125	∅5	14	57,5	14	70	3,5	12,7	276 459	750 315
	50(P25)	7,6	235	125	∅5	14	82,5	14	70	3,5	12,7	359 491	1 018 285

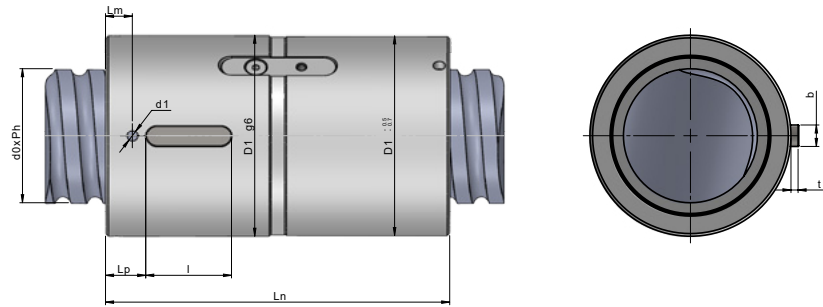

Recirculation system	Maximum speed coefficient
IN	100 000 / d <sub>0</sub>

Diameter d <sub>0</sub>	Pitch P <sub>h</sub>	Number of effective turns i	Length of the nut L <sub>n</sub>	Ball nut diameter D <sub>1</sub>	Lubrication hole d <sub>1</sub>	L <sub>m</sub>	L <sub>p</sub>	b	l	t <sub>1</sub>	Ball diameter D <sub>w</sub>	C <sub>am</sub>	C <sub>om</sub>
	mm	i	mm	mm	mm	mm	mm	mm	-		mm	[N]	[N]
25	5	3	74	40	∅3	7	9,5	5	16	2,1	3,5	16 010	31 617
	5	4	85	40	∅3	7	10,5	5	20	2,1	3,5	20 504	42 156
	10	2	95	40	∅3	8	12,5	5	20	2,1	3,5	11 214	20 960
	10	3	119	40	∅3	8	16	5	25	2,1	3,5	15 893	31 440
32	5	4	83	50	∅4	8	11	8	18	2,9	3,5	23 125	55 455
	5	5	95	50	∅4	8	13	8	20	2,9	3,5	28 017	69 318
	5	6	105	50	∅4	8	15,5	8	20	2,9	3,5	32 773	83 182
	6	3	84	50	∅3	8	11	8	18	2,9	3,969	21 736	47 741
	6	4	98	50	∅3	8	13,5	8	20	2,9	3,969	27 837	63 654
	6	5	107	50	∅3	8	13,5	8	25	2,9	3,969	32 727	79 568
	8	4	116	50	∅4	8,5	14	8	28	2,9	5	35 700	72 849
	8	5	130	50	∅4	9	15,5	8	32	2,9	5	43 252	91 061
	10	3	131	50	∅4	10	15,5	8	32	2,9	6,35	37 128	66 242
12	3	142	50	∅4	10	18,5	8	32	2,9	6,35	37 033	66 113	
40	5	4	85	63	∅4	8	11,5	8	18	2,9	3,5	25 750	70 973
	5	5	95	63	∅4	8	13	8	20	2,9	3,5	31 197	88 716
	5	6	107	63	∅4	8	13,5	8	25	2,9	3,5	36 493	106 459
	6	3	85	63	∅4	8	11	8	18	2,9	3,969	24 157	60 777
	6	4	96	63	∅4	8	13	8	20	2,9	3,969	30 937	81 037
	6	5	108	63	∅4	8	13,5	8	25	2,9	3,969	37 482	101 296
	8	3	108	63	∅4	9	13,5	8	25	2,9	5	31 746	71 593
	8	4	124	63	∅4	9	14	8	32	2,9	5	40 657	95 457
	8	5	138	63	∅4	9	17,5	8	32	2,9	5	49 258	119 321
	8	6	158	63	∅4	9	22,5	8	32	2,9	5	57 620	143 185
	10	3	128	63	∅4	10	17	8	28	2,9	6,35	43 004	88 036
	10	4	150	63	∅4	10	20,5	8	32	2,9	6,35	55 075	117 381

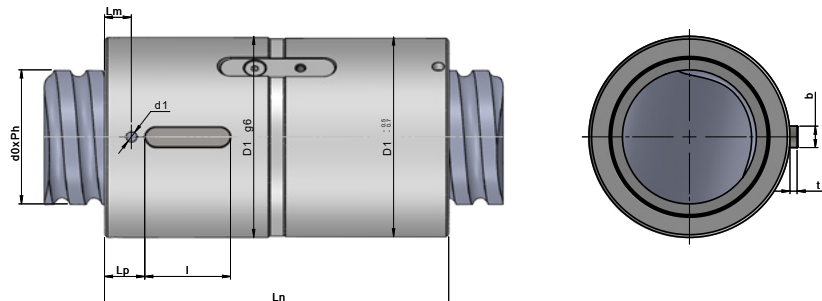

Recirculation system	Maximum speed coefficient
IN	100 000 / d <sub>0</sub>

Diameter d <sub>0</sub>	Pitch P <sub>h</sub>	Number of effective turns i	Length of the nut L <sub>n</sub>	Ball nut diameter D <sub>1</sub>	Lubrication hole d <sub>1</sub>	L <sub>m</sub>	L <sub>p</sub>	b	l	t <sub>1</sub>	Ball diameter D <sub>w</sub>	C <sub>am</sub>	C <sub>om</sub>
	mm	i	mm	mm	mm	mm	mm	mm	-	mm	mm	[N]	[N]
40	15	2	139	63	∅4	10	20	8	28	2,9	7,144	35 534	65 998
	15	3	174	63	∅4	10	26,5	8	32	2,9	7,144	50 360	98 997
	15	4	206	63	∅4	10	30,5	8	40	2,9	7,144	64 496	131 996
50	5	4	85	75	∅4	8	11,5	8	18	2,9	3,5	28 528	90 922
	5	5	93	75	∅4	8	12,5	8	20	2,9	3,5	34 564	113 652
	5	6	105	75	∅4	8	13	8	25	2,9	3,5	40 431	136 383
	8	3	108	75	∅4	9	13,5	8	25	2,9	5	36 251	95 297
	8	4	126	75	∅4	9	16,5	8	28	2,9	5	46 426	127 063
	8	5	140	75	∅4	9	20	8	28	2,9	5	56 248	158 828
	8	6	160	75	∅4	9	23	8	32	2,9	5	65 797	190 594
	10	3	128	75	∅4	10	15	8	32	2,9	6,35	48 931	115 375
	10	4	150	75	∅4	10	16,5	8	40	2,9	6,35	62 666	153 833
	10	5	170	75	∅4	10	21,5	8	40	2,9	6,35	75 924	192 291
10	6	192	75	∅4	10	27	8	40	2,9	6,35	88 812	230 750	

Diameter d <sub>0</sub>	Pitch P <sub>n</sub>	Number of effective turns i	Length of the nut L <sub>n</sub>	Ball nut diameter D <sub>1</sub>	Lubricati- on hole d <sub>1</sub>	L <sub>m</sub>	L <sub>p</sub>	b	l	t <sub>1</sub>	Ball diameter D <sub>w</sub>	C <sub>am</sub>	C <sub>om</sub>
	mm	i	mm	mm	mm	mm	mm	mm	-	mm	mm	[N]	[N]
50	12	4	174	75	ø4	11	22	10	40	3,3	7,938	82 121	182 879
	12	5	196	75	ø4	11	25	10	45	3,3	7,938	99 949	228 599
	12	6	224	75	ø4	11	32	10	45	3,3	7,938	116 384	274 318
	15	3	173	75	ø4	11	25,5	8	32	2,9	7,938	63 996	136 952
	15	4	204	75	ø4	11	30	8	40	2,9	7,938	81 960	182 602
	20	3	208	75	ø4	11	31	8	40	2,9	7,938	63 726	136 507
	20	4	254	75	ø4	11	42	8	40	2,9	7,938	81 614	182 009
63	10	3	132	90	ø5	11	19,5	10	25	3,3	6,35	54 639	148 343
	10	4	150	90	ø5	11	20,5	10	32	3,3	6,35	69 976	197 791
	10	5	170	90	ø5	11	25,5	10	32	3,3	6,35	84 780	247 239
	10	6	192	90	ø5	11	27	10	40	3,3	6,35	99 172	296 687
	12	4	180	90	ø5	11	24	10	40	3,3	7,938	93 194	239 758
	12	5	202	90	ø5	11	29,5	10	40	3,3	7,938	112 910	299 698
	12	6	230	90	ø5	11	34	10	45	3,3	7,938	132 077	359 637
	20	3	222	95	ø5	14	31,5	10	45	3,3	10,319	103 227	231 371
	20	4	262	95	ø5	14	29,5	10	70	3,3	10,319	132 203	308 494
80	10	4	154	105	ø5	14	17,5	12	32	3,1	7,144	93 008	292 569
	10	5	170	105	ø5	14	21,5	12	40	3,1	7,144	112 781	365 712
	10	6	194	105	ø5	14	27,5	12	40	3,1	7,144	131 926	438 854
	12	4	182	105	ø5	14	24,5	12	40	3,1	7,938	106 416	319 341
	12	5	204	105	ø5	14	30	12	40	3,1	7,938	128 929	399 176
	12	6	232	105	ø5	14	29	12	56	3,1	7,938	150 815	479 011
	20	3	245	125	ø5	14	25	14	70	3,5	12,7	147 896	346 843
	20	4	295	125	ø5	14	37	14	70	3,5	12,7	189 410	462 457
	20	5	325	125	ø5	14	45	14	70	3,5	12,7	229 480	578 071
	20	6	373	125	ø5	14	57	14	70	3,5	12,7	268 437	693 685

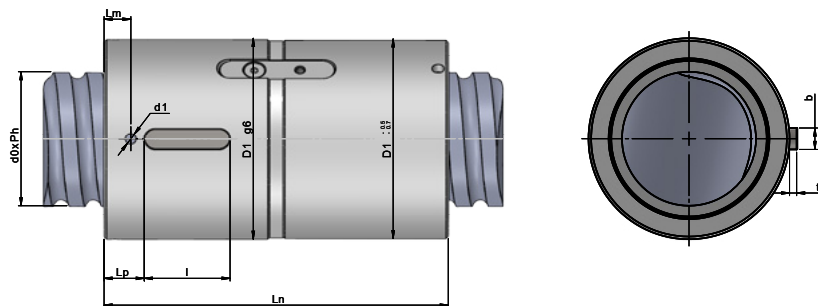

Recirculation system	Maximum speed coefficient
EX-A	125 000 / d <sub>0</sub>

Diameter d <sub>0</sub>	Pitch P <sub>h</sub>	Number of effective turns i	Length of the nut L <sub>n</sub>	Ball nut diameter D <sub>1</sub>	Lubrication hole d <sub>1</sub>	L <sub>m</sub>	L <sub>p</sub>	b	l	t <sub>1</sub>	Ball diameter D <sub>w</sub>	C <sub>am</sub>	C <sub>om</sub>
	mm	i	mm	mm	mm	mm	mm	mm	-	mm	mm	[N]	[N]
40	20	2,8	169	63	ø4	10	24,5	8	32	2,5	6,35	43 440	90 656
	20	3,8	209	63	ø4	10	30,5	8	40	2,5	6,35	56 487	123 033
	20(P10)	5,6	169	63	ø4	10	24,5	8	32	2,5	6,35	78 846	181 312
	20(P10)	7,6	209	63	ø4	10	30,5	8	40	2,5	6,35	102 527	246 066
	25	1,8	150	63	ø4	10	20,5	8	32	2,5	6,35	29 437	57 870
	25	2,8	200	63	ø4	10	29	8	40	2,5	6,35	43 045	90 020
	25(P12,5)	3,6	150	63	ø4	10	20,5	8	32	2,5	6,35	53 430	115 740
	25(P12,5)	5,6	200	63	ø4	10	29	8	40	2,5	6,35	78 128	180 040
	40	0,8	126	63	ø4	10	17	8	25	2,5	6,35	14 598	26 290
	40	1,8	206	63	ø4	10	29,5	8	40	2,5	6,35	29 319	59 151
	40	2,8	286	63	ø4	10	123	8	40	2,5	6,35	42 872	92 013
	40(P20)	1,6	126	63	ø4	10	50,5	8	25	2,5	6,35	26 495	52 579
40(P20)	3,6	206	63	ø4	10	83	8	40	2,5	6,35	53 216	118 303	
40(P20)	5,6	286	63	ø4	10	123	8	40	2,5	6,35	77 815	184 027	
50	30	1,8	173	75	ø4	10	66,5	8	40	2,5	6,35	33 041	74 154
	30	2,8	233	75	ø4	10	96,5	8	40	2,5	6,35	48 314	115 351
	30	3,8	293	75	ø4	10	126,5	8	40	2,5	6,35	62 825	156 548
	30(P15)	3,6	173	75	ø4	10	70,5	8	32	2,5	6,35	59 971	148 309
	30(P15)	5,6	233	75	ø4	10	96,5	8	40	2,5	6,35	87 692	230 703
	30(P15)	7,6	293	75	ø4	10	126,5	8	40	2,5	6,35	114 030	313 097
	30	1,8	173	82	ø4	10	70,5	8	32	2,5	7,144	40 993	91 339
	30	2,8	233	82	ø4	10	96,5	8	40	2,5	7,144	59 942	142 083
	30	3,8	293	82	ø4	10	126,5	8	40	2,5	7,144	77 945	192 827

Diameter d <sub>0</sub>	Pitch P <sub>h</sub>	Number of effective turns i	Length of the nut L <sub>n</sub>	Ball nut diameter D <sub>1</sub>	Lubricati- on hole d <sub>1</sub>	L <sub>m</sub>	L <sub>p</sub>	b	l	t <sub>1</sub>	Ball diameter D <sub>w</sub>	C <sub>am</sub>	C <sub>om</sub>
	mm	i	mm	mm	mm	mm	mm	mm	-		mm	[N]	[N]
50	30(P15)	3,6	173	82	ø4	10	70,5	8	32	2,5	7,144	74 404	182 678
	30(P15)	5,6	233	82	ø4	10	96,5	8	40	2,5	7,144	108 797	284 166
	30(P15)	7,6	293	82	ø4	10	126,5	8	40	2,5	7,144	141 473	385 654
	40	0,8	130	82	ø4	10	51	8	28	2,5	7,144	20 077	40 086
	40	1,8	210	82	ø4	10	85	8	40	2,5	7,144	40 326	90 194
	40	2,8	290	82	ø4	10	125	8	40	2,5	7,144	58 966	140 301
	40(P20)	1,6	130	82	ø4	10	51	8	28	2,5	7,144	36 441	80 172
	40(P20)	3,6	210	82	ø4	10	85	8	40	2,5	7,144	73 193	180 387
	40(P20)	5,6	290	82	ø4	10	125	8	40	2,5	7,144	107 026	280 602
63	30	2,8	236	95	ø5	12	95,5	10	45	3,5	7,938	73 810	189 012
	30	3,8	296	95	ø5	12	125,5	10	45	3,5	7,938	95 978	256 516
	30	4,8	356	95	ø5	12	155,5	10	45	3,5	7,938	117 335	324 020
	30	2,8	251	105	ø5	14	97,5	14	56	3,5	10,319	107 599	252 586
	30	3,8	311	105	ø5	14	127,5	14	56	3,5	10,319	139 915	242 795
	30	4,8	371	105	ø5	14	157,5	14	56	3,5	10,319	171 048	433 004
	40	1,8	215	95	ø5	12	85	10	45	3,5	7,938	51 267	125 339
	40	2,8	295	95	ø5	12	125	10	45	3,5	7,938	74 965	194 972
	40	3,8	375	95	ø5	12	165	10	45	3,5	7,938	97 480	264 605
	40(P20)	3,6	215	95	ø5	12	85	10	45	3,5	7,938	93 051	250 678
	40(P20)	5,6	295	95	ø5	12	125	10	45	3,5	7,938	136 063	389 944
	40(P20)	7,6	375	95	ø5	12	165	10	45	3,5	7,938	176 929	529 210
	40	1,8	228	105	ø5	14	86	14	56	3,5	10,319	72 822	161 082
	40	2,8	308	105	ø5	14	126	14	56	3,5	10,319	106 485	250 572
40	3,8	388	105	ø5	14	166	14	56	3,5	10,319	138 467	340 062	
80	16	2,8	167	125	ø5	14	55,5	14	56	3,5	10,319	120 522	322 532
	16	3,8	199	125	ø5	14	71,5	14	56	3,5	10,319	156 720	437 722
	16	4,8	231	125	ø5	14	87,5	14	56	3,5	10,319	191 593	522 912
	16	5,8	263	125	ø5	14	103,5	14	56	3,5	10,319	225 455	668 102
	20	2,8	190	125	ø5	14	67	14	56	3,5	10,319	120 356	322 189
	20	3,8	230	125	ø5	14	87	14	56	3,5	10,319	156 504	437 256
	20	4,8	270	125	ø5	14	107	14	56	3,5	10,319	191 328	552 324
	20	5,8	310	125	ø5	14	127	14	56	3,5	10,319	225 143	667 391
	25	2,8	232	125	ø5	14	88	14	56	3,5	10,319	120 097	321 655
	25	3,8	282	125	ø5	14	113	14	56	3,5	10,319	156 167	436 532
	25	4,8	332	125	ø5	14	138	14	56	3,5	10,319	190 916	551 409
	25	2,8	231	125	ø5	14	87,5	14	56	3,5	12,7	154 995	380 225
	25	3,8	281	125	ø5	14	112,5	14	56	3,5	12,7	201 547	516 019
	25	4,8	331	125	ø5	14	130,5	14	70	3,5	12,7	246 394	651 814

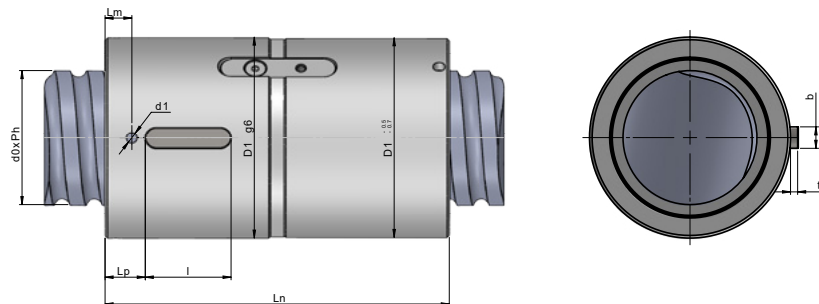

Recirculation system	Maximum speed coefficient
EX-A	125 000 / $d_0$

Diameter $d_0$	Pitch $P_h$	Number of effective turns $i$	Length of the nut $L_n$	Ball nut diameter $D_1$	Lubrication hole $d_1$	$L_m$	$L_p$	$b$	$l$	$t_1$	Ball diameter $D_w$	$C_{am}$	$C_{om}$
	mm	$i$	mm	mm	mm	mm	mm	mm	-	mm	mm	[N]	[N]
80	30	2,8	261	125	ø5	14	95,5	14	70	3,5	10,319	119 782	321 006
	30	3,8	321	125	ø5	14	125,5	14	70	3,5	10,319	155 757	435 651
	30	4,8	381	125	ø5	14	155,5	14	70	3,5	10,319	190 415	550 297
	30	5,8	441	125	ø5	14	185,5	14	70	3,5	10,319	224 069	664 942
	30	2,8	264	125	ø5	14	97	14	70	3,5	12,7	154 595	379 469
	30	3,8	324	125	ø5	14	127	14	70	3,5	12,7	201 026	514 993
	30	4,8	384	125	ø5	14	157	14	70	3,5	12,7	245 757	650 518
	30	5,8	444	125	ø5	14	187	14	70	3,5	12,7	289 193	786 043
	40	1,8	231	125	ø5	14	80,5	14	70	3,5	10,319	81 374	205 311
	40	2,8	311	125	ø5	14	120,5	14	70	3,5	10,319	118 990	319 372
	40	3,8	391	125	ø5	14	160,5	14	70	3,5	10,319	154 727	433 434
	40(P20)	3,6	231	125	ø5	14	80,5	14	70	3,5	10,319	147 698	410 622
	40(P20)	5,6	311	125	ø5	14	120,5	14	70	3,5	10,319	215 971	638 745
	40(P20)	7,6	391	125	ø5	14	160,5	14	70	3,5	10,319	280 836	866 868
	40	1,8	240	125	ø5	14	85	14	70	3,5	12,7	105 035	242 720
	40	2,8	320	125	ø5	14	125	14	70	3,5	12,7	153 587	377 565
	40	3,8	400	125	ø5	14	165	14	70	3,5	12,7	199 716	512 409
	40(P20)	3,6	240	125	ø5	14	85	14	70	3,5	12,7	190 642	485 440
	40(P20)	5,6	320	125	ø5	14	125	14	70	3,5	12,7	278 766	755 129
	40(P20)	7,6	400	125	ø5	14	165	14	70	3,5	12,7	362 492	1 024 818
	50	1,8	278	125	ø5	14	104	14	70	3,5	12,7	104 165	241 173
	50	2,8	378	125	ø5	14	154	14	70	3,5	12,7	152 316	375 158
	50	3,8	478	125	ø5	14	204	14	70	3,5	12,7	198 062	509 143
	50(P25)	3,6	278	125	ø5	14	104	14	70	3,5	12,7	189 064	482 346
50(P25)	5,6	378	125	ø5	14	154	14	70	3,5	12,7	276 459	750 315	
50(P25)	7,6	478	125	ø5	14	204	14	70	3,5	12,7	359 491	1 018 285	

## 4.2 Basic screw

Transport ball screws are used for applications with less emphasis on the high precision of positioning, e.g. trans-

port or lifting equipment, woodworking machines, etc. The screw thread is rolled.

Basic technical parameters:

- Diameter up to 63 mm
- Accuracy classes T5, T7
- Minimum strength of the shaft material  $R_m = 650 \text{ MPa}$
- Efficiency approx. 93–95%
- Operating temperature  $-20 \text{ }^\circ\text{C}$  to  $+60 \text{ }^\circ\text{C}$  (acc. to the lubricant type)

Application:

- Transport mechanisms
- Woodworking machine tools
- Industrial automation
- Others

Category characteristics:

- Very good quality/price ratio
- Standard geometrical and working accuracy, lifetime and load ratings in accordance with ISO 3408



### 4.3 Heavy duty screw

Heavy duty ball screws provide more than double load capacity and rigidity compared to the standard ball screws due to a modified radius of the thread profile.

The high-load ball screws have lower efficiency and are designed for slow-running applications only. The high-load ball screws are usually produced as non-preloaded.

Basic technical parameters:

- The recommended thread diameter range from 40 to 200 mm
- Minimum strength of the shaft material is  $R_m = 900 \text{ MPa}$
- Efficiency approx. 93–95%
- These ball screws should be lubricated by lubricants for high loads
- Dynamic loads up to 4,000,000 N

Category characteristics:

- Ball screws for high axial loads

Application

- Injection molding machines
- Electric presses
- Lifting equipment
- Replacements of hydraulic cylinders
- Others



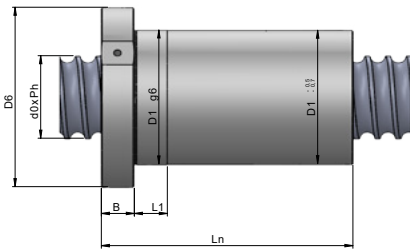

FLANGE TYPE 1

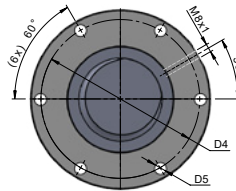

FLANGE TYPE 2

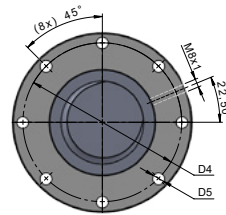

Recirculation system	Maximum speed coefficient
IN	100 000 / $d_0$

Diameter $d_0$	Pitch $P_h$	Number of effective turns $i$	Length of the nut $L_n$	Ball nut diameter $D_1$	$L_1$	Flange diameter $D_6$	Flange width $B$	$D_4$	$D_5$	Flange type	Lubrication hole	Ball diameter $D_w$	$C_{am}$	$C_{om}$
	mm													
40	12	6	123	70	18	104	18	86	9	1	M8x1	7,938	149 000	335 000
50	12	8	149	77	20	111	20	94	9	1	M8x1	7,938	222 000	595 000
	16	8	196	95	28	135	28	113	9	1	M8x1	12,7	382 000	863 000
63	16	8	201	105	28	139	28	122	9	1	M8x1	12,7	448 000	1 146 000
	16	10	237	105	28	139	28	122	9	1	M8x1	12,7	543 000	1 433 000
	20	8	250	117	28	157	28	137	11	1	M8x1	15,875	572 000	1 350 000
80	16	8	202	120	32	158	32	139	9	1	M8x1	12,7	518 000	1 525 000
	20	8	244	125	32	165	32	145	11	1	M8x1	15,875	669 000	1 793 000
100	20	12	337	145	32	185	32	165	11	2	M8x1	15,875	1 097 000	3 574 000
	20	15	412	145	40	185	40	165	11	2	M8x1	15,875	1 330 000	4 467 000
	25	10	370	160	40	212	40	189	17,5	2	M8x1	20,638	1 306 000	3 779 000
125	20	12	360	180	40	232	40	206	17,5	2	M8x1	15,875	1 248 000	4 682 000
	20	15	430	180	40	232	40	206	17,5	2	M8x1	15,875	1 512 000	5 853 000
	25	10	370	190	40	238	40	212	17,5	2	M8x1	20,638	1 454 000	4 727 000
140	25	12	445	200	50	252	50	226	17,5	2	M8x1	20,638	1 872 000	6 782 000
	32	12	540	220	50	272	50	246	17,5	2	M8x1	25,4	2 403 000	8 003 000
160	25	15	550	220	60	272	60	246	17,5	2	M8x1	20,638	2 432 000	9 886 000
	32	12	570	230	60	282	60	256	17,5	2	M8x1	25,4	2 558 000	9 151 000

## 4.4 Special screw

The special ball screw category includes e.g. these variants:

### Telescopic ball screw:

- Used in applications where small housing dimensions and large pitches are required (e.g. handling platforms, hexapods, etc.).
- It is a telescopic set of several ball screws screwed in one assembly. The ball nuts work as bearings supporting the inner ball screw assembly.
- The telescopic ball screws replace hydraulic cylinders with the advantage of easy control and positioning.



Telescopic ball screw

### Threadless ball screw:

- The threadless ball screw is intended especially for motion mechanisms of manipulators and transport equipment, which require efficient transmission of the rotary to linear motion without emphasis on the rigidity and load capacity, but with requirements on simplicity, easy maintenance, and undemanding manufacturability.



Threadless ball screw

### Linear actuator:

- The linear actuator ensures motor controlled linear movement within the operating range; it replaces the hydraulic cylinders. It uses the transmission of the rotary to linear motion using the ball screw with minimum efficiency of 95 %.
- The movement speed can be controlled or adjusted by a suitable selection of the used.



Linear actuator

- The profiled thread is used only for the ball nut and the forces are transmitted via the balls inserted between this profile and the smooth cylindrical profile of the shaft. To transmit the forces, this solution uses elastic deformation of the hardened and ground cylindrical shaft, on which the preloaded balls in the profiled inner thread of the nut are rolling.

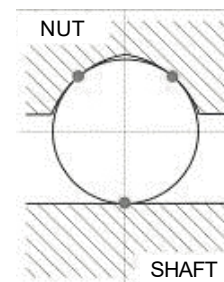

Threadless ball screw operation

If you are interested in any of the above mentioned designs, we will be pleased to provide you with our technical support.



KSK is a sought-after partner for precision machine tool manufacturers worldwide. You will get this position thanks to its reliability, excellent quality and smart selection.

- The up-to-date catalogue version is always available on the company website in section Downloads.
- General terms and conditions as well as operating conditions can be found on the company website in section Downloads.
- Most of the used calculations are based on the ISO 3408 standard dealing with ball screws.
- Due to continuous technical development within our company, the technical parameters quoted in this catalogue are not binding on the KSK Precise Motion, a.s. company.
- The KSK Precise Motion, a.s. company hereby declares that it bears no liability for incorrect design proposals made by customers based on the data contained in this catalogue. If you need assistance, please contact our technical support.



#### FACTORY BUILDING

KSK Precise Motion, a.s.  
Blanenská 1277/37  
664 34 Kuřim  
Czech Republic

Phone: +420 533 033 710  
E-mail: [info@ksk-pm.cz](mailto:info@ksk-pm.cz)